



MONROE COUNTY  
**R O A D**  
COMMISSION

---

840 S. Telegraph Road • Monroe, Michigan 48161 • Phone: (734) 240-5102 • Fax: (734) 240-5101

**PROPOSAL**  
  
**FOR**  
  
**2017 PAVEMENT MARKING PROGRAM**

**BID OPENING:**

Friday, March 31, 2017 at 10:00 a.m.

BOARD OF COUNTY ROAD COMMISSIONERS  
OF THE COUNTY OF MONROE

Paul Iacoangeli, Chairman  
Dan Minton, Vice Chairman  
Charles A. Londo , Member  
Stephen J. Pace, Member  
Greg Stewart, Member

**MONROE COUNTY ROAD COMMISSION  
INVITATION TO BID**

Sealed bids will be received by the Board of County Road Commissioners of the County of Monroe until **10:00 a.m.** local time on **Friday, March 31, 2017** at their office located at 840 South Telegraph Road, Monroe, Michigan, 48161 for the following:

- 2017 Asphalt Rejuvenating Surface Treatment Program
- 2017 Fog Seal Program
- 2017 Full Depth Reclamation Program
- 2017 HMA Paving Program
- 2017 Pavement Marking Program
- 2017-2018 Supplemental Grader Services

Bids will be publicly opened and read aloud by the Bid Committee at 10:00 a.m. Proposals may be downloaded from the Road Commission's website at [www.mcrc-mi.org/bids.html](http://www.mcrc-mi.org/bids.html).

BOARD OF COUNTY ROAD COMMISSIONERS  
OF THE COUNTY OF MONROE, MICHIGAN

**MONROE COUNTY ROAD COMMISSION  
PROPOSAL  
2017 PAVEMENT MARKING PROGRAM**

TO: The Board of County Road Commissioners of the County of Monroe, Michigan

FOR: 2017 Pavement Marking Program – Countywide pavement marking for Monroe County, Michigan

Ladies and Gentlemen:

The undersigned bidder hereby affirms that:

1. The proposal is in all respects fair and without any collusion or fraud.
2. The undersigned have examined the site of the proposed project and have made a personal investigation and estimate of quantities.
3. The undersigned will contract to furnish all labor, equipment, tools and material necessary for the complete construction of the above described project at the unit prices stated on the attached bid forms and to complete the work in the time specified to the satisfaction of the Board of County Road Commissioners of the County of Monroe, Michigan.

Company: \_\_\_\_\_

Address: \_\_\_\_\_

City, State, ZIP: \_\_\_\_\_

Telephone: \_\_\_\_\_

By: \_\_\_\_\_

Title: \_\_\_\_\_

Date: \_\_\_\_\_

NOTE: If the bidder is a co-partnership, each member must sign the proposal.

Corporations must execute the proposal by duly authorized officers in accordance with Articles of Incorporation.

INSTRUCTIONS TO BIDDERS  
and  
GENERAL CONDITIONS

The Michigan Department of Transportation 2012 Standard Specifications for Construction are incorporated as part of these bidding documents and shall govern except as provided in the Invitation to Bid, Instructions to Bidders and General Conditions, Proposal, Contract, Supplemental Specifications, Special Provisions and Plans. Reference to the Department or Commission in the Michigan Department of Transportation 2012 Standard Specifications for Construction shall for this project mean the Board of County Road Commissioners of the County of Monroe, hereinafter referred to as "Board", unless otherwise specified.

OWNER

The owner of the project is the Board of County Road Commissioners of the County of Monroe, also referred to as the "Board."

ENGINEER

The Engineer is the County Highway Engineer or the individual assigned by the County Highway Engineer to be in charge of the project. The person assigned as the Project Engineer may be an employee of the board, a consultant or an outside contractor hired by the Board.

BIDDER

The Bidder is one who submits a signed bid with the required documentation directly to the Board at the time and place specified.

BID FORMS

Sealed proposals must be submitted on the bid forms furnished by the Board. The proposal shall be submitted in its entirety with no modifications or changes except as authorized by an addendum and with no pages removed. Unit prices as listed will govern in determining the correct total of the bid. All proposals must be filled out in ink or typewritten and shall be legibly signed, giving the complete name and address of the bidder.

All bids must be in a sealed envelope and clearly marked "**Bid for 2017 Pavement Marking Program**". Bids failing to meet this requirement will not be considered.

OPENING OF BIDS

Bids will be received by the Board of Monroe County Road Commissioners at 840 S. Telegraph Road, Monroe, Michigan, 48161, until **10:00 A.M.**, local time on **Friday, March 31, 2017**, at which time they will be publicly opened and read aloud.

BIDDER'S SURETY

Each proposal must be accompanied by a cashier's check, certified check, or a bid bond made payable to the Board of County Road Commissioners of Monroe County, Michigan, in the sum of five percent (5%) of the amount of the bid. Upon awarding and signing of a contract, or in the event of bid rejection, such bid surety will be returned to the bidder. Bids may be held for a period of forty (40) days.

ACCEPTANCE AND/OR REJECTION OF BIDS

The Board reserves the right to accept, reject and/or modify any or all bids, to waive irregularities therein, and to make the award in any manner deemed to be in the best interest of the Monroe County Road Commission.

TITLE VI ASSURANCE

The Monroe County Road Commission, in accordance with Title VI of the Civil Rights Act of 1964 (78 Stat. 252, 42 USC 2000d to 2000d-4) and Title 49, Code of Federal Regulations, Part 21, as they may be amended from time to time, hereby notifies all bidders that it assures that in any contract entered into pursuant to this advertisement, minority business enterprises will be afforded full opportunity to submit bids in response to this invitation and will not be discriminated against on the grounds of race, color, national origin, gender, age, or disability in consideration for an award.

PROHIBITION OF DISCRIMINATION

In accordance with Act No. 453, Public Acts of 1976, the Contractor and subcontractors hereby agree not to

discriminate against an employee or applicant for employment with respect to hire, tenure, terms, conditions, or privileges of employment, or a matter directly or indirectly related to employment, because of race, color, religion, national origin, age, sex, height, weight, or marital status. Further, in accordance with Act No. 220, Public Acts of 1976 as amended by Act No. 478, Public Acts of 1980, the Contractor and subcontractors hereby agree not to discriminate against an employee or applicant for employment tenure, terms, conditions, or privileges of employment, or a matter directly or indirectly related to employment, because of a disability that is unrelated to the individual's ability to perform the duties of a particular job or position. A breach of the above covenants shall be regarded as a material breach of this contract.

#### CONTRACT EXECUTION

The bidder to whom the contract is awarded shall, within ten (10) calendar days, after notice of award, enter into a written contract with the Board of Monroe County Road Commissioners and furnish bonds as hereinafter specified. Failure to execute a contract or furnish satisfactory bonds will be considered cause for annulment of award and forfeiture of the proposal guarantee. Please note that this contract is a one year contract and will last for the year of 2016.

#### PERFORMANCE AND LIEN BONDS

The successful bidder to whom the contract is awarded shall furnish two (2) surety bonds as follows:

- A. Performance Bond - To the Board of Monroe County Road Commissioners for the faithful fulfillment of the terms of the contract in the amount of one-hundred percent (100%) of the total contract amount.
- B. Lien Bond - To the Board of Monroe County Road Commissioners for the payment of all labor and materials used in the work in the amount of fifty percent (50%) of the total contract amount.

#### INCREASED OR DECREASED QUANTITIES

The Board of Monroe County Road Commissioners reserves the right to increase or decrease quantities from those originally estimated and such changes will be paid for at the unit price bid so long as the total contract amount is not changed more than ten percent (10%). Changes in excess of that amount will be individually negotiated.

#### CALLBACK PROVISION FOR PAVEMENT MARKING CONTRACT

The Contractor will be required to make a minimum of two (2) trips this year. The first trip phase (Phase I) will be the primary part of the pavement marking program and the second trip (Phase II) will be in the late Fall to provide paint for roads which have been resurfaced in the interim. To finish out the contract, a third trip in the following spring may be required if severe weather has faded out some markings. Exact dates shall be determined by the Monroe County Road Commission Engineering Department. There will be no callback or mobilization fee paid for Phase II trips or spring trips, regardless of mileage.

#### TIME OF COMPLETION

For Phase I, all work is to be completed no later than **August 31, 2017**.

For Phase II, all work is to be completed not later than **November 15, 2017** unless approved by the Monroe County Road Commission Engineering Department.

#### PAYMENTS TO CONTRACTOR

The Contractor shall invoice the Monroe County Road Commission for their work on the contract. The invoice shall contain, at a minimum, the following information: road name and limits, the quantities of work completed and the contract unit prices.

#### FINAL INSPECTION, ACCEPTANCE AND FINAL PAYMENT

The engineer will make a final inspection of all work included in the contract each year, and notify the contractor of defects to be remedied prior to final acceptance for that year. Upon satisfactory completion of the work by the contractor, a yearly final estimate will be prepared. Payment for all work completed and accepted, less previous payments, will be made within thirty (30) days of final acceptance.

#### DISPUTES

The County Highway Engineer's written decision on any question arising under the contract between the

Board and Contractor shall be final and binding upon both the Board and the Contractor in the absence of fraud, bad faith, or abuse of discretion.

#### ARBITRATION

All claims, disputes and other matters in question between the Board and the Contractor arising out of, or relating to, the Contract Documents or the breach thereof (except for claims which have been waived by the making or acceptance of final payment) will be decided by arbitration in accordance with the Construction Industry Arbitration Rules of the American Arbitration Association then obtaining subject to the limitations of this section. This agreement so to arbitrate and any other agreement or consent to arbitrate entered into in accordance herewith will be specifically enforceable under the prevailing laws of any court having jurisdiction.

No demand for arbitration of any claim, dispute or other matter that is required to be referred to Engineer initially for decision will be made until the earlier of (a) the date on which Engineer has rendered a decision or (b) the tenth day after the parties have presented their evidence to Engineer if a written decision has not been rendered by Engineer before that date. No demand for arbitration of any such claim, dispute or other matter will be made later than thirty (30) days after the date on which Engineer has rendered a written decision in respect thereof; and the failure to demand arbitration within said thirty (30) days' period shall result in Engineer's decision being final and binding upon Board and Contractor. If Engineer renders a decision after arbitration proceedings have been initiated, such decision may be entered as evidence but will not supersede the arbitration proceedings, except where the decision is acceptable to the parties concerned. No demand for arbitration of any written decision of Engineer will be made later than ten (10) days after the party making such demand has delivered written notice of intention to appeal.

Notice of the demand for arbitration will be filed in writing with the other party to the Agreement and with the American Arbitration Association, and a copy will be sent to Engineer for information. The demand for arbitration will be made within the thirty (30) day or ten (10) day period specified above as applicable, and in all other cases within a reasonable time after the claim, dispute or other matter in question has arisen, and in no event shall any such demand be made after the date when institution of legal or equitable proceedings based on such claim, dispute or other matter in question would be barred by the applicable statute of limitations.

No arbitration arising out of or relating to the Contract Documents shall include by consolidation, joinder or in any other manner any other person or entity who is not a party of this contract unless:

- a) the inclusion of such other person or entity is necessary if complete relief is to be afforded among those who are already parties to the arbitration;
- b) such other person or entity is substantially involved in a question of law or fact which is common to those who are already parties to the arbitration and which will arise in such proceedings, and;
- c) the written consent of the other person or entity sought to be included and of Board and Contractor has been obtained for such inclusion, which consent shall make specific reference to this paragraph; but no such consent shall constitute consent to arbitration of any dispute not specifically described in such consent or to arbitration with any party not specifically identified in such consent.

Notwithstanding the above paragraph, if a claim, dispute or other matter in question between Board and Contractor involves the Work of a Subcontractor, either Board or Contractor may join such Subcontractor as a party to the arbitration between Board and Contractor hereunder. Contractor shall include in all subcontracts a specific provision whereby the Subcontractor consents to being joined in arbitration between Board and Contractor involving the Work of such Subcontractor. Nothing in this paragraph nor in the provision of such subcontract consenting to joinder shall create any claim, right or cause of action in favor of Subcontractor and against Board or Board's Consultants that does not otherwise exist.

The award rendered by the arbitrators will be final, judgment may be entered upon it in any court having jurisdiction thereof, and it will not be subject to modification or appeal.

#### FAILURE TO COMPLETE ON TIME

Liquidated damages will be assessed in accordance with Section 108.11 of the Michigan Department of Transportation Standard Specifications for Construction (2012 Edition). For the purpose of charging

liquidated damages, this project will be assessed using the time of completion dates provided within this document and each phase will be assessed individually.

#### PROGRESS SCHEDULE

In no case shall any work be commenced prior to receipt of formal notice of award by the Board.

The low Bidder for the work covered by this proposal will be required to meet with the Board's representative to review the Contractor's proposed work schedule. The schedule for this meeting will be set within one (1) week after the low Bidder is determined.

The Board's representative will arrange the time and place for the meeting.

#### TAXES

The Contractor shall include, and will be deemed to have included, in its base bid and contract price all applicable Michigan Sales and Use taxes which have been enacted into law as of the date the bid is submitted.

#### BOARD RESPONSIBILITY

The Board shall not supervise, direct or have control or authority over, nor be responsible for, Contractor's means, methods, techniques, sequences or procedures of construction or the safety precautions and programs incident thereto, or for any failure of Contractor to comply with laws and regulations applicable to the furnishing or performance of the work unless otherwise specified in the Special Provisions. Board will not be responsible for Contractor's failure to perform or furnish the Work in accordance with the Contract Documents.

#### INDEMNIFICATION, DAMAGE LIABILITY AND INSURANCE

**Indemnification.** The Contractor must hold harmless, indemnify, defend and represent the Board and its officers, agents and employees against any and all claims for bodily injury or property damage, or any other claim arising out of performance of the work on this contract. The Contractor will not be responsible for claims that result from the sole negligence or willful acts of said indemnitee.

**Workers' Compensation Insurance.** The Contractor must carry the necessary Workers' Compensation Insurance and submit a certification that it carries Workers' Compensation to the Board.

**Bodily Injury and Property Damage.** The Contractor must carry adequate insurance, satisfactory to the Board, to afford protection against all claims for damage to public or private property and injuries to persons arising out of performance of the work. Copies of completed certificates must be submitted to the Board.

1. **General Liability, Bodily Injury and Property Damage.** The Contractor must provide the following minimum limits of property damage and bodily injury liability:

Bodily Injury and Property Damage Liability:	
Each Occurrence	\$1,000,000
Aggregate	\$2,000,000

2. **Automobile Liability, Bodily Injury and Property Damage.** The Contractor must provide the following minimum limits of property damage and bodily injury liability:

Bodily Injury and Property Damage Liability:	
Each Person	\$500,000
Each Occurrence	\$1,000,000

Property Damage Liability:	
Each Occurrence	\$1,000,000

Combined Single Limit for Bodily Injury and Property Damage Liability:	
Each Occurrence	\$2,000,000

3. **Umbrella Policy.** The Contractor may meet the requirements of above minimum limits of bodily injury and property damage liability through an umbrella policy.

**Additional Insured and Endorsement.** The Bodily Injury and Property Damage Policy must include the following endorsements, verbatim:

“Additional Insured: The Board of County Road Commissioners of the County of Monroe, the Monroe County Road Commission and its officers, agents and employees.”

“Provide written notice ten (10) days prior to cancellation, expiration, termination or reduction in coverage for nonpayment of the premium and written notice thirty (30) days prior to cancellation, expiration, termination or reduction in coverage for all other reasons.”

**Notice.** The Contractor must ensure that all insurance policies and binders include an endorsement by which the insurer agrees to notify the Department in writing at least 30 days before there is a cancellation or material change in coverage. The Contractor must stop operations if any insurance is canceled or reduced, and must not resume operations until new issuance is in force.

**Reports.** The Contractor or insurance carrier shall report to the Board any claims received, inspections made and the disposition of claims. The Board will withhold final payment release until either the Contractor pays the claim or until final disposition of the claim by the Contractor’s insurance company has been received by the Board.

#### SPECIFICATIONS

All work not otherwise specified shall be done in accordance with the Michigan Department of Transportation 2012 Standard Specifications for Construction. Within these specifications all references to the Michigan Department of Transportation shall mean the Board.

#### MATERIALS

All materials to be incorporated into the project shall be per the Michigan Department of Transportation *Material Source Guide* and/or as otherwise permitted by the BOARD. The CONTRACTOR shall submit MDOT form 0501 *Materials Source List* for all materials to be used on the PROJECT prior to use, for review and approval.

#### COMMUNICATIONS

Any questions regarding this bid shall be directed to the Monroe County Road Commission’s purchasing agent listed below:

Name: Christine Herron  
Phone: 734-240-5109  
Email: CHerron@mcrc-mi.org



**FOR INFORMATIONAL PURPOSES ONLY**

Waterborne Pavement Marking Paint is to be used for the pavement marking in this contract.

For the bidders' information, to be used for reference only, the roads to be striped have a total road mileage of approximately 350 miles per year. The majority, centerline work for roads not scheduled for construction, will be completed prior to the Phase I deadline of August 31. The remainder, roads scheduled for construction and edgeline work, will be completed during Phase II and completed prior to the deadline of November 15.

The sections of road to be striped are located throughout the county. In addition, there are approximately 30 intersections each year that are to be striped on each approach for a distance of 500 feet. Lineal footage for those intersections is included in the contract total. The intersections for each year are to be completed during Phase I unless part of construction areas. This list is provided in this document as Attachment A.

The contractor will be furnished a map and log of roads to be striped in Phase I at a pre-construction meeting. In the past, there has been a time delay between the preconstruction meeting and the actual start of Phase I striping. As such, the Monroe County Road Commission reserves the right to change the Phase I striping up to the actual start of the painting.

Normally each year the contractor on the Monroe County Road Commission pavement marking contract also stripes those roads for the Villages and Cities at the same unit bid price as on the Monroe County Road Commission contract and bills the municipalities individually for the striping done for each municipality. At the time the contractor does the Phase I striping on this Monroe County Road Commission contract, the Village of South Rockwood normally has about 4 miles of striping to be done, the Village of Maybee has about 4 miles or more, the Village of Dundee has about 4 miles, the City of Luna Pier, about 1 mile, the City of Milan will have about 12 miles the City of Petersburg has about 1½ miles of striping and the Village of Estral Beach has about 1 mile. Contact information for these entities is Attachment B.

The bidder is hereby requested to advise the Monroe County Road Commission at the time of submitting their bid document for this contract if they will not be able to perform the striping mileages for the Villages and Cities mentioned above.

**MONROE COUNTY ROAD COMMISSION  
UNIT PRICE BID  
2017 PAVEMENT MARKING PROGRAM  
Waterborne Pavement Marking Material**

TO: Board of County Road Commissioners of Monroe County, Michigan

The undersigned, having full knowledge of the site, proposal, plans and specifications for the **2017 Pavement Marking Program** in Monroe County, Michigan including Bidders' Addenda \_\_\_\_\_ and the conditions of these Contract Documents, hereby agrees to furnish all services, labor, materials, tools, equipment, transportation, and incidentals necessary to perform the entire Work; to complete the contract by the date specified in the Instructions to Bidders and General Provisions, according to the Proposal, Plans and Specifications, and to accept in full, compensation for all work necessary to complete the project at the unit prices named below:

<b>ITEMIZED PROPOSAL</b>
--------------------------

ITEM	ITEM OF WORK	APPROX. QUANTITY	UNIT	UNIT PRICE BID	TOTAL AMOUNT BID
1	4" Solid Yellow Line (No Pass Zone)	1,030,000	LFT		
2	4" Skip Yellow Line (Center Line)	1,550,000	LFT		
3	4" Solid White Line (Edge Line)	830,000	LFT		
4	4" Skip White Line (Lane Line)	25,000	LFT		
5	6" Solid White Line (Edge Line)	50,000	LFT		

TOTAL OF BID: \_\_\_\_\_  
Use words

\_\_\_\_\_ Dollars

Contractor Signature: \_\_\_\_\_

Printed Name and Title: \_\_\_\_\_

Quantities are not guaranteed. Final payment will be based on actual quantities.

Bidder agrees that the work will be completed and ready for final payment in accordance with the General Conditions. All work on the **2017 Pavement Marking Program** is to be completed by **November 15, 2017** as detailed in the Time of Completion section above.

Bidder accepts the provisions of the Agreement as to liquidated damages in the event of failure to complete the work on time.

The following documents are attached to and made a condition of this Bid:

Required Bid Security in the form of either:

Certified Check or a Bidder's Bond in the amount of:

\_\_\_\_\_ Dollars (\$ \_\_\_\_\_)

Communications concerning this Bid shall be addressed to the Bidder's representative.

Name of Representative: \_\_\_\_\_

Address: \_\_\_\_\_

City, State, ZIP: \_\_\_\_\_

Telephone Number: \_\_\_\_\_

Fax Number: \_\_\_\_\_

E-Mail Address: \_\_\_\_\_

The terms used in this Bid, which are defined in subsection 101.03 of the Michigan Department of Transportation 2012 Standard Specifications of the Construction, have the meanings assigned to them in the Standard Specifications for Construction.

SUBMITTED on: \_\_\_\_\_, 2017

**SPECIAL PAVEMENT MARKINGS (OPTIONAL)  
FOR INFORMATIONAL PURPOSES ONLY**

This project will consist of the following approximate materials, quantities and pay items.

The Monroe County Road Commission has decided to bid out the special pavement marking in the 2017 season. In the past, all work of this type had been completed using in house crews, materials and equipment. As such, we currently do not have a known budget for this work. This project bid will encompass the work normally completed by our work force.

The Monroe County Road Commission will bid out two options – 1. Special Markings using Waterborne Paint and 2. Special Markings using Polyurea Paint. In both cases, the Monroe County Road Commission will supply the stencils required for the work to be completed. We will use this information and our current budget to decide which option to choose.

For the bidders' information, to be used for reference only, all work completed prior to the Phase I deadline of August 31 (approximately 70% of work) includes work on roads not a part of the 2017 Monroe County Road Commission construction program. The remainder, roads scheduled for construction, will be completed during Phase II and completed prior to the deadline of November 15.

For bidding purposes, our in house lists of special pavement marking locations is provided in this document as Attachment C.

The contractor will be furnished a list of those special markings in Phase I at a pre-construction meeting. In the past, there has been a time delay between the preconstruction meeting and the actual start of Phase I work. As such, the Monroe County Road Commission reserves the right to change/add to Phase I marking up to the actual start of the painting.

**MONROE COUNTY ROAD COMMISSION  
UNIT PRICE BID  
2017 PAVEMENT MARKING PROGRAM – SPECIAL MARKINGS (OPTIONAL)**

**Polyurea Pavement Marking Material**

**ITEMIZED PROPOSAL**

ITEM	ITEM OF WORK	APPROX. QUANTITY	UNIT	UNIT PRICE BID	TOTAL AMOUNT BID
1	Pavt, Mrkg, Polyurea, Railroad Symbol	250	EA		
2	Pavt, Mrkg, Polyurea, 24 inch, Stop Bar	10,000	FT		
3	Pavt, Mrkg, Polyurea, Lt Turn Arrow Sym	180	EA		
4	Pavt, Mrkg, Polyurea, Rt Turn Arrow Sym	45	EA		
5	Pavt, Mrkg, Polyurea, Only	150	EA		
6	Pavt, Mrkg, Polyurea, School	70	EA		
7	Pavt, Mrkg, Polyurea, Thru Arrow Sym	2	EA		

**Waterborne Pavement Marking Material**

**ITEMIZED PROPOSAL**

ITEM	ITEM OF WORK	APPROX. QUANTITY	UNIT	UNIT PRICE BID	TOTAL AMOUNT BID
1	Pavt, Mrkg, Waterborne, Railroad Symbol	250	EA		
2	Pavt, Mrkg, Waterborne, 24 inch, Stop Bar	10,000	FT		
3	Pavt, Mrkg, Waterborne, Lt Turn Arrow Sym	180	EA		
4	Pavt, Mrkg, Waterborne, Rt Turn Arrow Sym	45	EA		
5	Pavt, Mrkg, Waterborne, Only	150	EA		
6	Pavt, Mrkg, Waterborne, School	70	EA		
7	Pavt, Mrkg, Waterborne, Thru Arrow Sym	2	EA		

Contractor Signature: \_\_\_\_\_

Printed Name and Title: \_\_\_\_\_

Quantities are not guaranteed. Bidder agrees that the unit cost for these items are valid until the project

completion date of November 15, 2017. Final payment will be based on actual quantities. (Note - we anticipate that the contractor will have to mobilize at least 3 trips – Phase I, Phase II early, Phase II late. Please include mobilization into the unit costs as it will not be paid as an extra work item.)

Bidder agrees that the work will be completed and ready for final payment in accordance with the General Conditions. All work on the **2017 Pavement Marking Program – SPECIAL MARKINGS** is to be completed by **November 15, 2017** as detailed in the Time of Completion section above.

Bidder accepts the provisions of the Agreement as to liquidated damages in the event of failure to complete the work on time.

The following documents are attached to and made a condition of this Bid:

Required Bid Security in the form of either:

Certified Check or a Bidder's Bond in the amount of:

\_\_\_\_\_ Dollars (\$ \_\_\_\_\_)

Communications concerning this Bid shall be addressed to the Bidder's representative.

Name of Representative: \_\_\_\_\_

Address: \_\_\_\_\_

City, State, ZIP: \_\_\_\_\_

Telephone Number: \_\_\_\_\_

Fax Number: \_\_\_\_\_

E-Mail Address: \_\_\_\_\_

The terms used in this Bid, which are defined in subsection 101.03 of the Michigan Department of Transportation 2012 Standard Specifications of the Construction, have the meanings assigned to them in the Standard Specifications for Construction.

SUBMITTED on: \_\_\_\_\_, 2017

**SPECIAL PROVISION  
FOR  
PAVEMENT MARKING APPLICATIONS**

Description

This work covers the furnishing and application of reflectorized pavement markings as specified by the Engineer, the proposal, and/or plans.

Equipment

The pavement marker shall be trucked mounted and capable of applying three (3) yellow 4-inch minimum width centerlines or one (1) white 4-inch minimum width edge lines in one pass of the equipment. The equipment shall have sufficient paint and bead capacity to enable sustained pavement marking operations and shall be equipped so as to assure uniform application of the paint and beads. The equipment shall have pressurized bead dispensers. In general, the equipment shall be that necessary to accomplish the marking in a safe and efficient manner. The department reserves the right to inspect the bidders equipment before making an award of contract.

All vehicles used in marking operation in traffic shall be equipped with rotating or oscillating flashers, which are visible from both the front and rear of the vehicle and an illuminated Target Arrow, capable of being visible from either the front or rear of the vehicle.

The contractor shall use an accurate dashing mechanism, capable of being easily adjusted, to retrace existing lane or centerline markings as specified in the plans or as directed by the Engineer. The contractor shall equip the pavement marking machine with a method of measuring the flow rate of the material to the applied line. Flowmeter, graduated tanks, or other method approved by the Engineer is acceptable of measuring flow rate. The contractor's equipment shall include linear footage meter to measure the length of applied line. The Engineer may check calibration of any metering device at the department's discretion.

**MATERIALS**

Description

The specification covers white and yellow ready-mixed paints to be used with pressure spray equipment to mark either Portland cement or bituminous concrete pavements. The paints shall be suitable for spray application without thinning when heated at temperatures up to 110° F and shall also be suitable for retaining glass beads applied by the drop-on method.

The paints shall be uniformly ground and, with reasonable redispersion, be suitable for application after a year of outdoor storage.

Paint Ingredients

The traffic paint ingredients shall meet the following requirements. Unless specified otherwise, the values required for the ingredients are in percent by weight.

<u>Ingredients</u>	<u>White</u>	<u>Yellow</u>
<u>Pigment:</u>		
<i>Titanium Dioxide Pigment, Type III (Rutile) ASTH D 476</i>	24-28	-----
<i>Chrome Yellow, Type III, ASTH D 211</i>	-----	30-34
<i>Calcium Carbonate, Type GC, Grade I or II, ASTH D 1199</i>	48-52	48-52
<i>Magnesium Silicate, ASTH D 605</i>	20-24	14-18
<i>Pigment Suspending Agent, Fed. Spec/ TT-P-115c</i>	0.4-0.5	0.4-0.5
<u>Vehicle:</u>		
<i>Alkyd Resin Solids, Type I, Fed. Spec. TT-P-115c, except that a minimum phiallic anhydride content of 34 percent</i>	41.5	41.5
<i>VH L P Haptha, Type 1, Fed. Spec. TT-P-115c</i>	41-43	41-43
<i>High-Volatile Petroleum Thinner (Specific Gravity at 60/60 F: 0.680 to 0.700; Initial Boiling Point:</i>	17 max	17 max

118 to 150 F; Dry Point: 200F max):  
 Driers, Fed. Spec. TT-P-115c; and Anti-Skinning  
 Agents, Fed. Spec. TT-P-115c

c. Finished Paint – The finished paint shall meet the following requirements. Unless otherwise noted, tests used for determining compliance with the requirements shall be in accordance with Federal Standard No. 141.

	<u>White</u>	<u>Yellow</u>
Pigment, percent by weight	55-58	56-59
Vehicle, percent by weight	45 max	44 max
Fineness of Grind, Hegman	3 min	3 min
Weight per Gallon at 77 F, lb.	11.7 min	12.1 min
Consistency, Viscosity at 77 F, KU	80-95	80-95
Drying Time, minutes to no-pick-up, on stripes tested under laboratory conditions with beads dropped on the stripes at a rate of 6 lb/gal. Laboratory tests will be conducted in accordance with ASTH D 711.	30 max	30 max
*Bleeding, ASTH D 969, Asphalt Substrate Test Panel, beaded stripes	4 min	4 min
*Settling, ASTH 869	6 min	6 min
Reflectance, ASTH E 97, daylight 45 deg, 0 deg luminous directional reflectance, percent	80 min	-----
<u>Color</u> – The color of yellow paint shall be within the limits of the Color Tolerance Chart for Highway Yellow, PR Color #1 of the Federal Highway Administration, except that the green tolerance limit shall have C.I.E. coordinates of $x=0.491$ and $y=0.460$ , and except that the minimum lightness shall be 50.7 percent. Tests may be conducted in accordance with ASTH E308, using Standard Illuminant C or by visual comparison with color standards. Fluorescence in paints will not be permitted.		
Flexibility and Adhesion, Water Resistance, *Skinning, and *Condition in the Container shall be as specified in Fed. Spec. TT-P-115c.		

\*Properties preceded with an asterisk are not usually performed for acceptance testing.

Marking

Each container shall plainly show in weather resistant markings, the name of the producer description of the material, batch number, date of packaging, and volume of contents.

CONTROL OF MATERIALS

Section 105.05 of the 2012 Standard Specifications for Construction and the following special provisions will apply:

The materials used shall meet the department's current minimum specification requirements, herein.

Written certification from the supplier that the paints meets MDOT requirements will be required prior to being applied to the roadway. The County reserves the right to sample and test the material if required by the Engineer. Should the paint fail to comply with the specifications, the contract shall be required to reapply with materials that meet specifications at no cost to the County.

Storage

The County will not provide buildings to store contractor's materials and equipment; however, arrangements can be made to store materials and equipment on County right-of-ways. The contractor is responsible for disposing of all containers and waste material.

CONSTRUCTION METHODS

General

Pavement markings shall be Waterborne/Polyurea paint applied on bituminous or concrete surfaces.



Markings shall be either white or yellow in the lengths and widths specified in this proposal or as directed by the Engineer. Typical pavement marking lane line applications are illustrated in Part III of the Michigan Manual of Uniform Traffic Control Devices.

#### Skip Line

Skip lines of the color specified shall be applied as a 4-inch wide line on a cycle of 12 ½-foot segments and 37 ½-foot gaps. The paint shall be applied uniformly at a minimum rate of four (4) gallons of paint per mile of skip line.

#### Solid Line

Solid line of the color specified shall be applied as a solid 4-inch wide line. The paint shall be applied uniformly at a minimum rate of sixteen (16) gallons per mile of solid line.

### APPLICATION METHODS

#### General

Markings shall be applied so that they adhere adequately to the surface. Glass beads for reflectorization for Waterborne pavement marking shall be applied uniformly on all markings in accordance with the 2012 Standard Specifications for Construction. Glass beads shall be applied to the wet marking material so that the beads are uniformly embedded and retained in the material and uniformly cover the surface of the marking material to the point where there are loose beads on the surface of the wet line.

#### Surface Preparation

Prior to the application of pavement marking, it shall be the contractor's responsibility that the pavement surfaces are clean, dry, and free of all foreign materials. The contractor shall be responsible for removal of heavy and/or hardened deposits of foreign material, not easily removed by a power broom, such as, but not limited to, shoulder pullback gravel, or gravel deposits on the roadway.

#### Loading Paint Machine

The paint and beads shall be loaded on the paint machine in a manner that will not interfere nor delay traffic.

#### Layout for Marking

All layout work necessary for the location and placing of pavement markings shall be the responsibility of the Engineer.

#### Tolerances

New markings shall be applied as specified. Unless otherwise directed, existing markings are to be retraced with markings of equal length, allowing for a longitudinal tolerance of one-foot and a transverse of two-inches. The width applied shall be the width specified plus or minus 1/4 inch.

Applied markings shall be sharp, well defined, provide uniform retro reflectivity, be free of uneven edges, over spray, or other readily visible defects which, in the opinion of the Engineer, detract from the appearance or function of the pavement markings.

Markings, which are improperly located, shall be corrected. Improperly located markings shall be removed at the contractor's expense, in a manner acceptable to the Engineer and reapplied in the correct locations at the contractor's expense.

Markings which are applied with material shortages exceeding six (6%) percent of the specified application rates shall be properly reapplied at the contractor's expense or be subject to acceptance with applied deduction as provided in Deduction of Material Deficiencies.

### Weather and Seasonal Limitations

Markings in the Lower Peninsula shall be applied during the period of April 1 to November 15; and in the Upper Peninsula, during the period of May 1 to November 1; unless otherwise approved in writing by the Engineer.

Paint shall be applied when the surface temperature of the pavement is 50 degrees Fahrenheit or higher and the pavement is dry. The Contractor shall be responsible for making the decision to apply paint on any specific day when there is a high probability of rain in the forecast. If applied lines are washed away because of rain the Contractor shall be responsible for re-applying the lines at no additional expense to the Monroe County Road Commission.

### Placement and Protection of Pavement Markings

If markings are applied when the roadway is open to traffic, the following requirements shall apply:

Traffic shall be allowed to keep moving at all times and the striping equipment shall be operated in a manner that will not make it necessary for traffic to cross the uncured markings.

On two-lane, two-way roadways, the contractor will not be allowed to apply the centerline(s) and edge line in one (1) pass. The centerline(s) on two-lane, two-way roadways shall be applied with the paint machine and back-up vehicles straddling the center of the roadway. In all other cases, the paint machine shall occupy the travel lane adjacent the marking being applied.

The protection of the wet paint shall be the responsibility of the contractor. The contractor may furnish a pavement marking convoy consisting of a minimum of three (3) moving vehicles, spaced and equipped as indicated on the PAVEMENT MARKING CONVOY illustration sheets, in order to provide adequate traffic control and protection for the uncured markings. Markings obliterated by traffic shall be retraced at the contractor's expense.

### Method of Measurement

The method of measuring quantities for payment shall be as follows:

Skip line will be measured by the number of linear feet provided. This measurement will include the line and the adjacent gap.

Solid lines will be measured by the number of linear feet provided. Where no passing zones overlap, each solid line will be measured separately.

The contractor shall cooperate with the Engineer in providing these measurements whenever requested. The marking application rate shall be determined by the Engineer. Any determination of pay deduction resulting from shortages in marking quantities shall be based on the measurements obtained by this method. The glass bead application rate will be determined by dividing the total pounds glass used by the total gallons of paint applied.

The quantity of pavement marking material and glass beads applied per unit of measurement will be computed by the Engineer at the end of each day's work.

### Basis of Payment

These items will be paid for at the contract unit price for Waterborne Markings, legends, and symbols, of the color, width, and type specified.

Cleaning of the road surface shall be incidental to the project. Removal of existing thermoplastic and/or cold plastic material shall be considered incidental to the project.

### Deduction for Material Deficiencies

A daily tolerance of six (6%) percent for material shortages shall be permissible without deductions. Any determination of pay deduction resulting from shortages in marking materials or glass beads shall be based on measurements obtained under Measurement and Payment.

If the six (6%) percent tolerance has been exceeded on material shortages, the markings shall be reapplied at the contractor's expense or the contract until price will be reduced in direct proportion to the greatest deficiency up to a maximum of fifteen (15%) percent. If the deficiency of any material is more than fifteen (15%) percent, the days work shall be considered unsatisfactory and shall be reapplied at full expense to the contractor, including all labor, equipment, and material requirements.

Any reapplied markings shall be applied at the minimum gallons per mile rate described in Construction Methods.

Payment for accepted quantities complete in place will be made at contract unit prices, or prices adjusted as described herein. Payment shall be full compensation for all materials, labor, incidentals, and equipment necessary for placement of the fast dry marking material.

#### Final Acceptance

Final acceptance of approved completed markings shall be ninety (90) days after completion of all original work.

Unacceptable markings shall be reapplied with markings conforming to these specifications and requirements to the extent determined by the Engineer, at the contractor's expense.

- NOTES: 1. All letters are 16 inches wide unless noted otherwise.  
 2. All gaps between letters are 4 inches unless noted otherwise.  
 3. Rectangular area containing legend indicates template for liquid applied materials.

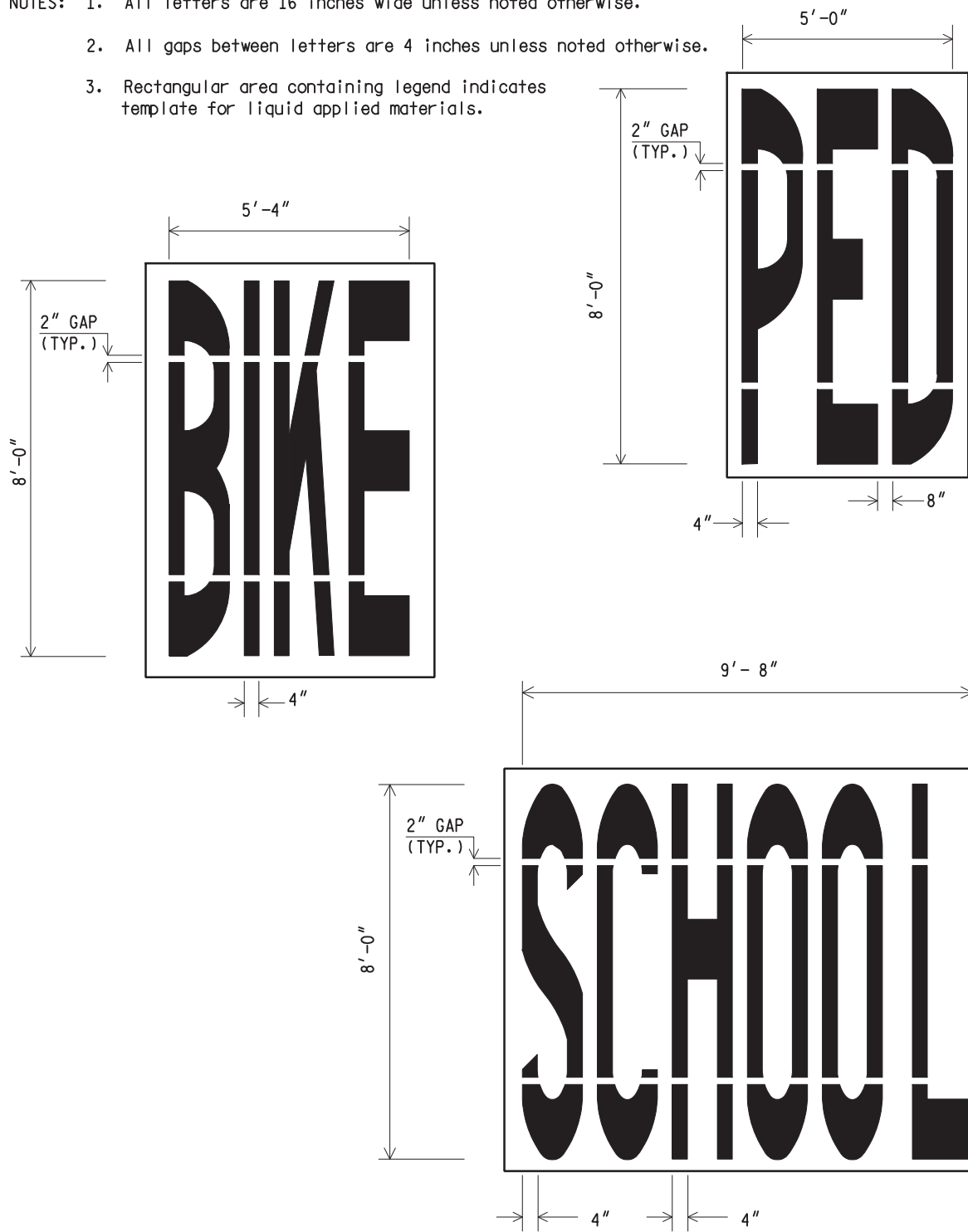

**LEGEND DETAILS**

 PREPARED BY DESIGN DIVISION DRAWN BY: <u>LME</u> CHECKED BY: <u>JGM</u>	DEPARTMENT DIRECTOR Kirk T. Steudle APPROVED BY: <u>Randy U. Piffel</u> DIRECTOR, BUREAU OF FIELD SERVICES	MICHIGAN DEPARTMENT OF TRANSPORTATION BUREAU OF HIGHWAY DEVELOPMENT STANDARD PLAN FOR <b>PAVEMENT ARROW          &amp; MESSAGE DETAILS</b>		
	APPROVED BY: <u>Mark A. Van Pelt</u> DIRECTOR, BUREAU OF HIGHWAY DEVELOPMENT	01/20/12 F.H.W.A. APPROVAL	10/18/11 PLAN DATE	PAVE-900-B SHEET 1 OF 7

- NOTES: 1. All letters are 16 inches wide unless noted otherwise.  
 2. All gaps between letters are 4 inches unless noted otherwise.  
 3. Rectangular area containing legend indicates template for liquid applied materials.

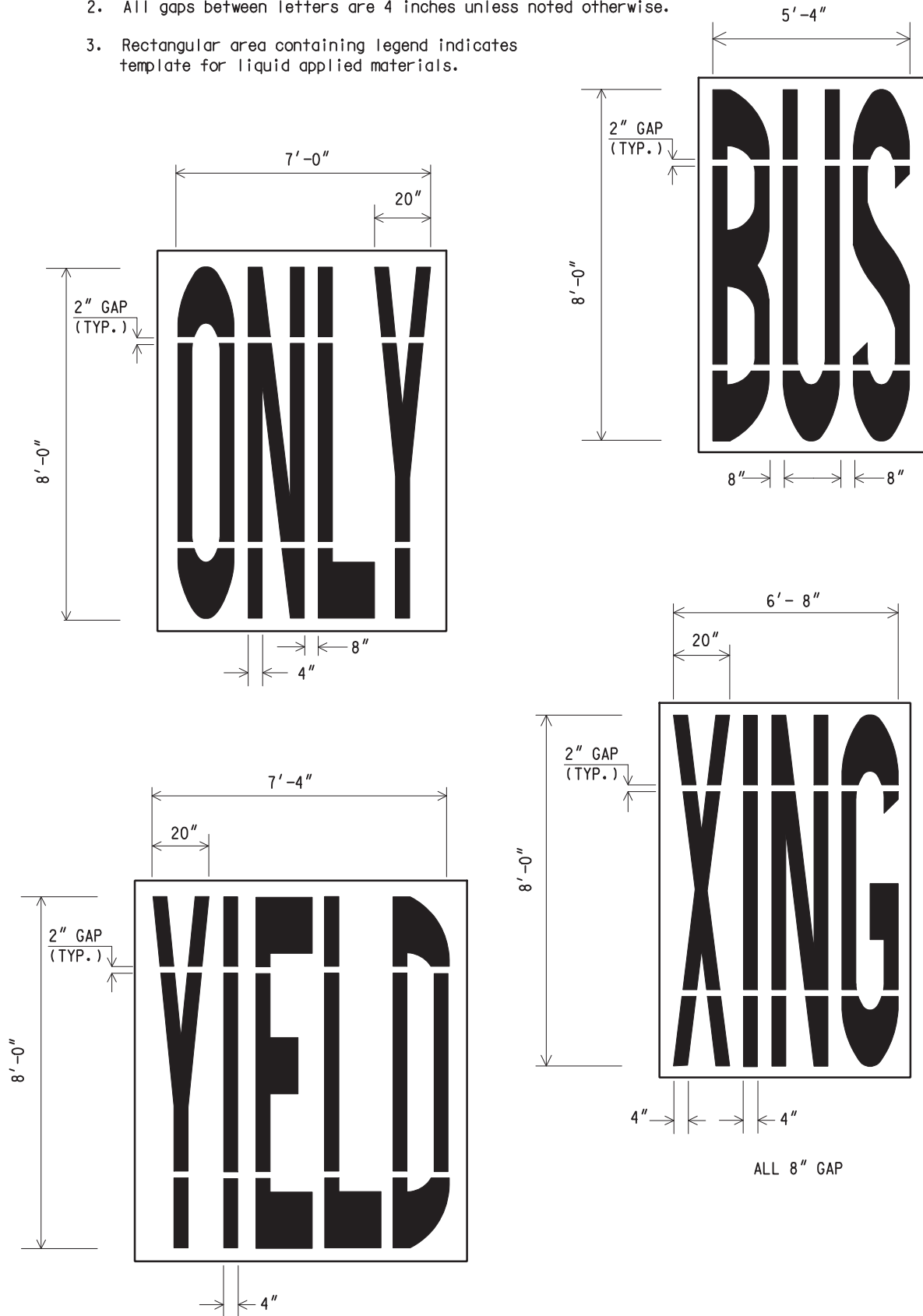

**LEGEND DETAILS**

NOT TO SCALE

MICHIGAN DEPARTMENT OF TRANSPORTATION  
 BUREAU OF HIGHWAY DEVELOPMENT STANDARD PLAN

01/20/12  
 F.H.W.A. APPROVAL

10/18/11  
 PLAN DATE

PAVE-900-B

SHEET  
 2 OF 7

- NOTES: 1. All letters are 16 inches wide unless noted otherwise.
2. Rectangular area containing legend indicates template for liquid applied materials.

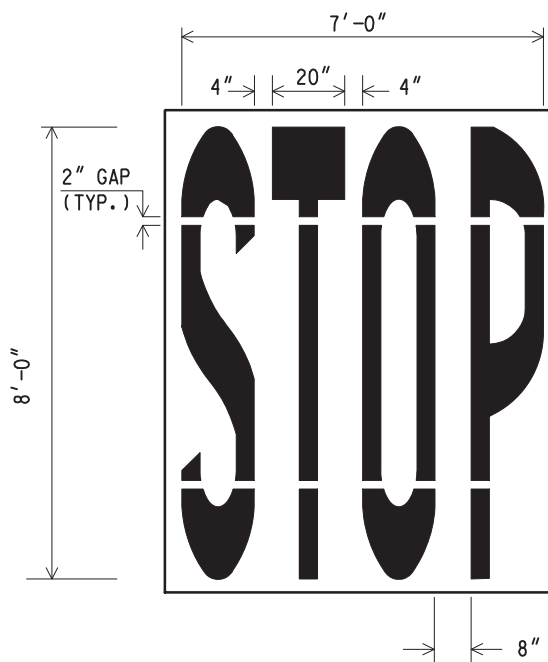
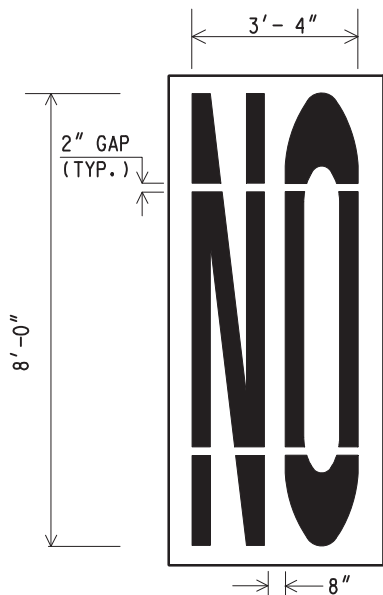
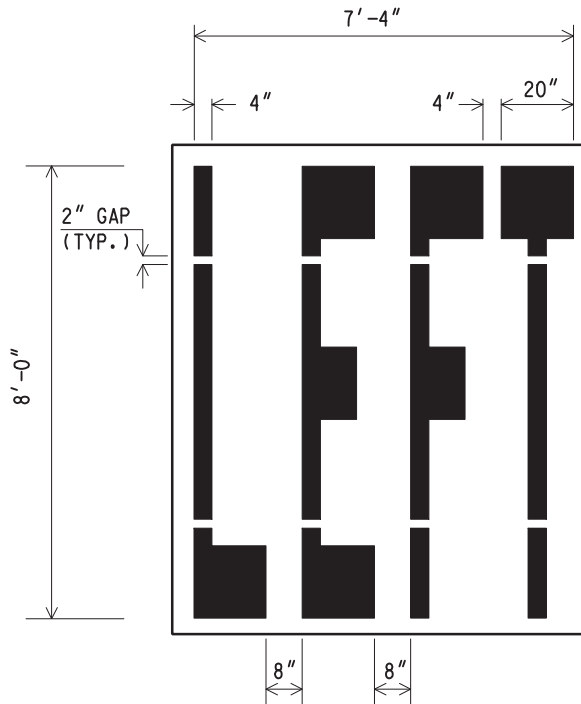
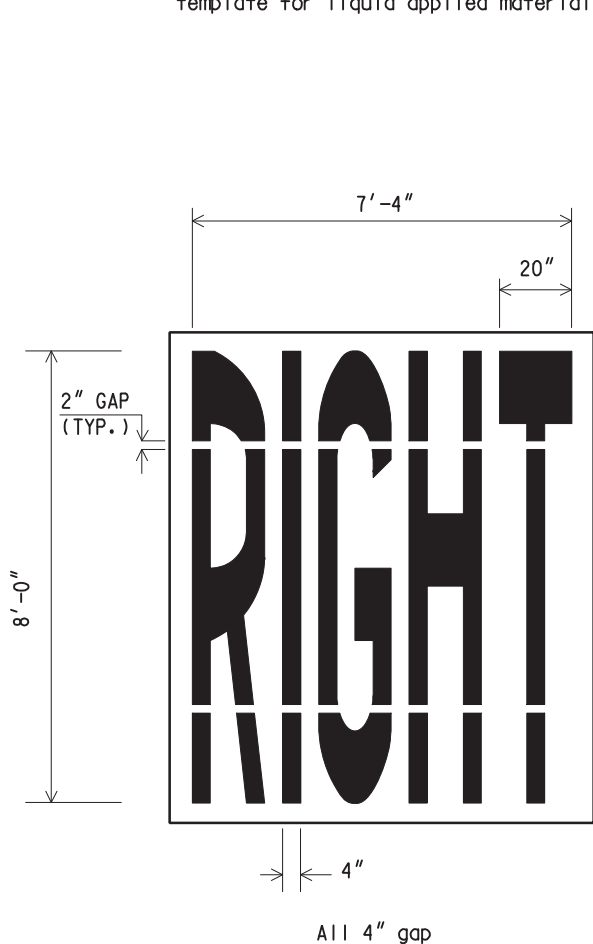

## LEGEND DETAILS

NOT TO SCALE

MICHIGAN DEPARTMENT OF TRANSPORTATION  
BUREAU OF HIGHWAY DEVELOPMENT STANDARD PLAN

01/20/12  
F.H.W.A. APPROVAL

10/18/11  
PLAN DATE

PAVE-900-B

SHEET  
3 OF 7

- NOTES: 1. All letters are 16 inches wide unless noted otherwise.
2. Rectangular area containing legend indicates template for liquid applied materials.

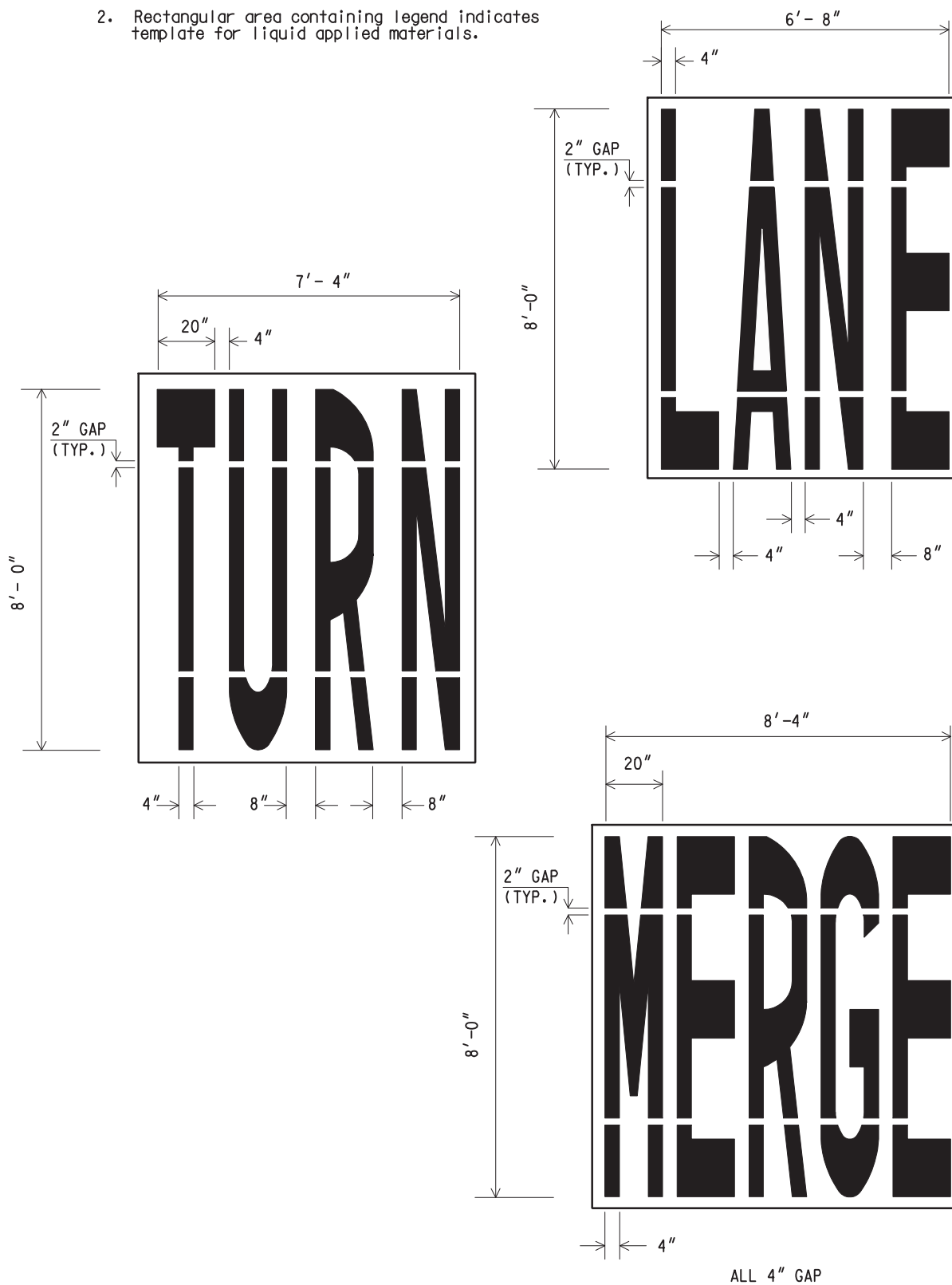

## LEGEND DETAILS

NOT TO SCALE

MICHIGAN DEPARTMENT OF TRANSPORTATION  
BUREAU OF HIGHWAY DEVELOPMENT STANDARD PLAN

01/20/12  
F.H.W.A. APPROVAL

10/18/11  
PLAN DATE

PAVE-900-B

SHEET  
4 OF 7

NOTE: Templates for liquid applied materials on this sheet do not allow gaps.

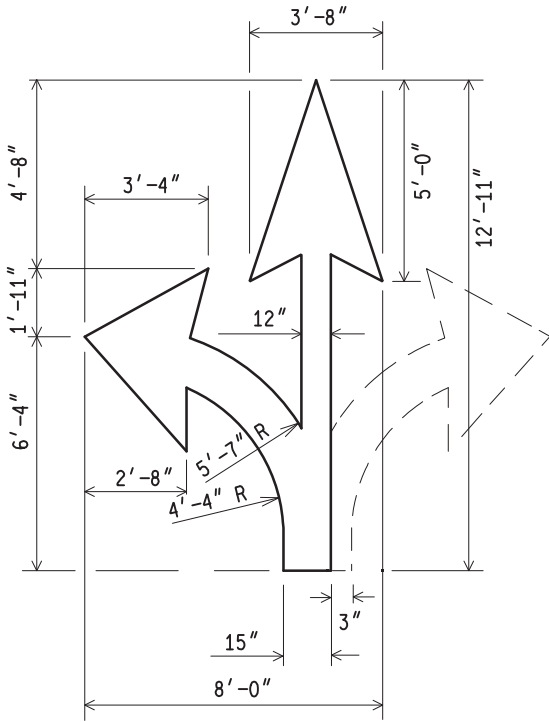

THRU RIGHT/LEFT TURN ARROW

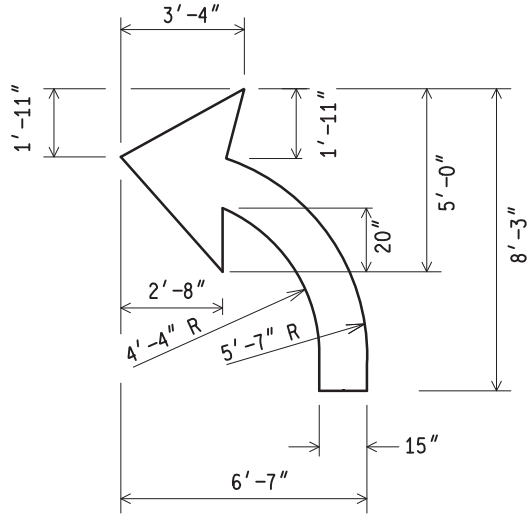

LEFT TURN ARROW  
(RIGHT TURN ARROW TO BE REVERSE)

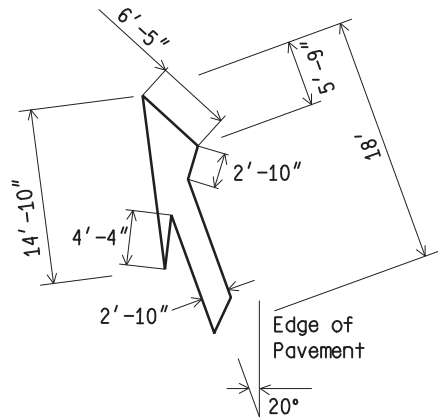

MERGE ARROW

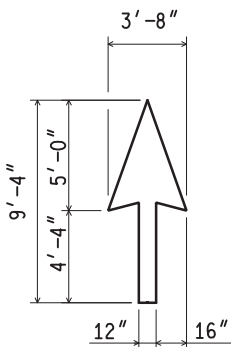

THRU ARROW

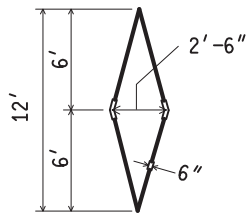

DEDICATED LANE SYMBOL

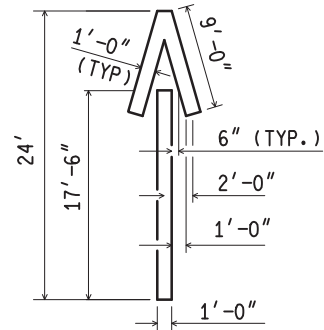

WRONG WAY ARROW

## PAVEMENT ARROW DETAILS

NOT TO SCALE

MICHIGAN DEPARTMENT OF TRANSPORTATION  
BUREAU OF HIGHWAY DEVELOPMENT STANDARD PLAN

01/20/12  
F.H.W.A. APPROVAL

10/18/11  
PLAN DATE

PAVE-900-B

SHEET  
5 OF 7

NOTE: THE ORIGINAL SIGNED COPY IS KEPT ON FILE AT THE MICHIGAN DEPARTMENT OF TRANSPORTATION.



NOTE: Templates for liquid applied materials on this sheet do not allow gaps.

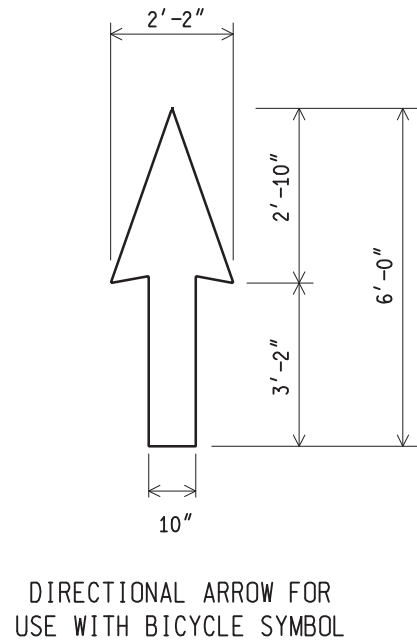
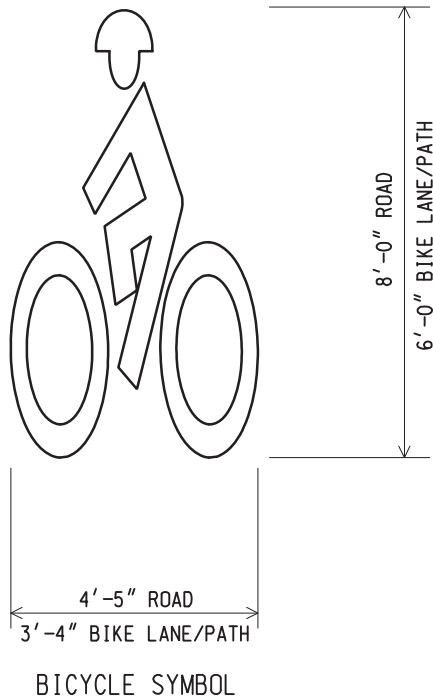

### SPECIAL MARKING REMOVAL AREAS

LEGEND	AREA IN FT <sup>2</sup>	SYMBOL	AREA IN FT <sup>2</sup>
BIKE	43	BICYCLE (ROAD)	24
BUS	43	BICYCLE (LANE/PATH)	16
LANE	53	DEDICATED LANE (HOV)	11
LEFT	59	WRONG WAY ARROW	13
MERGE	67	DIRECT. ARROW (BIKE)	9
NO	27	HANDICAP	8
NO LEFT TURN	145	LEFT, RIGHT ARROW	28
ONLY	56	LT, RT, THRU ARROW	41
PED	40	MERGE ARROW	24
RIGHT	59	RAILROAD	64
SCHOOL	77	RAILROAD-ALTERNATE	75
STOP	56	ROUNDBOUT ARROW	40
TURN	59	THRU ARROW	12
XING	53	THRU, LT TURN ARROW	29
YIELD	59	THRU, RT TURN ARROW	29
		TURN ARROW, LT OR RT	16

NOT TO SCALE

MICHIGAN DEPARTMENT OF TRANSPORTATION  
BUREAU OF HIGHWAY DEVELOPMENT STANDARD PLAN

01/20/12  
F.H.W.A. APPROVAL

10/18/11  
PLAN DATE

PAVE-900-B

SHEET  
6 OF 7

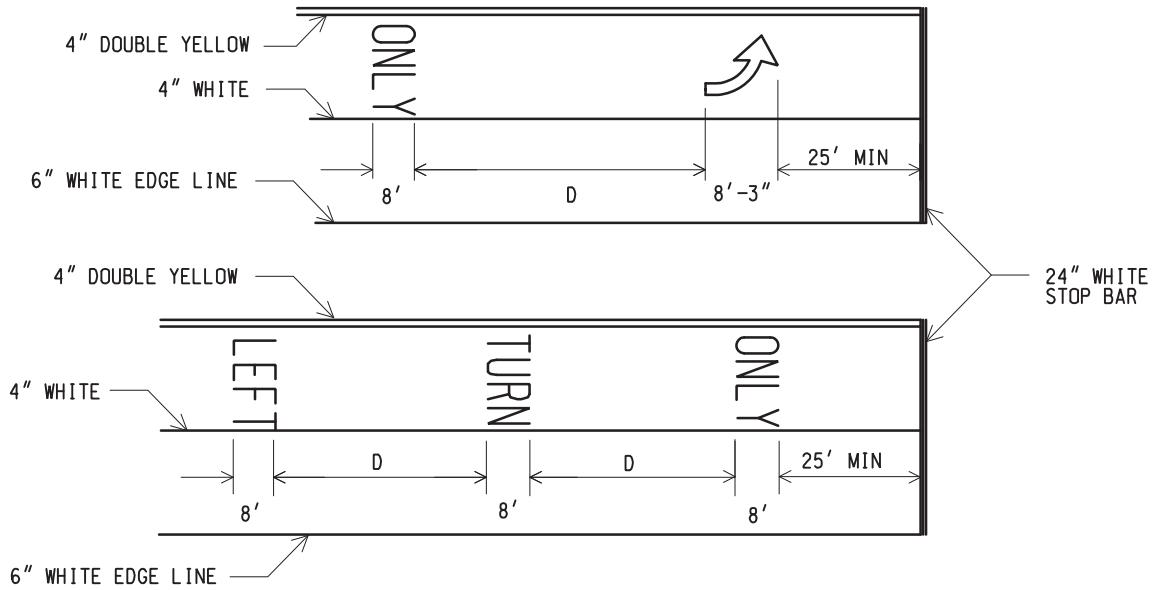

## TYPICAL SPACING OF ARROW AND PAVEMENT MESSAGES

POSTED SPEED (MPH)	DISTANCE "D" (FT)
25 AND BELOW	32
30-35	48
40-45	64
50 AND ABOVE	80

**NOTES:**

1. All special markings (arrow, message and symbol) shall be white.
2. When arrow and pavement message are used together, the arrow should be located downstream of the pavement message and separated from the pavement message by a distance of "D" (measured from the top of the message to the base of the arrow) as shown above.
3. When a series of pavement messages are used, they should be separated by a distance of "D" related to the posted speed, as shown in the table above. All symbols and legends shall be positioned in the center of the lane.

NOT TO SCALE

MICHIGAN DEPARTMENT OF TRANSPORTATION BUREAU OF HIGHWAY DEVELOPMENT STANDARD PLAN	01/20/12 <small>F.H.W.A. APPROVAL</small>	10/18/11 <small>PLAN DATE</small>	PAVE-900-B	SHEET 7 OF 7
--	--	--------------------------------------	------------	-----------------

NOTE: THE ORIGINAL SIGNED COPY IS KEPT ON FILE AT THE MICHIGAN DEPARTMENT OF TRANSPORTATION.

100' MINIMUM OR AS DETERMINED BY  
 $L = S \times W$  WHERE W IS THE LATERAL  
 OFFSET IN FEET AND S IS THE POSTED  
 SPEED IN MPH (FOR 45 MPH OR MORE)  
 OR BY  $L = (WS^2) / 60$  (FOR 40 MPH OR LESS)

YELLOW ANGLED TRANSVERSE MARKINGS  
 (OPTIONAL). SEE DETAIL "A" BELOW.  
 USE SHOULD BE BASED ON RECOMMENDATION  
 OF THE TRAFFIC ENGINEER.

SEE LEFT TURN LANE MARKINGS DETAIL  
 DRAWINGS FOR LOCATION AND DIMENSIONS  
 OF ARROW AND LEGEND MARKINGS  
 (SEE PAVE-935-SERIES)

75' MINIMUM AS SHOWN OR A REVERSE CURVE  
 DOUBLE 4" YELLOW LINE MAY BE INSTALLED

SEE LONGITUDINAL LINES DETAIL DRAWING

SEE STOP LINE DETAIL DRAWING

OPTIONAL ARROW AND LEGEND (TYP.)  
 SEE ARROW AND LEGEND DETAIL DRAWINGS  
 (SEE PAVE-935-SERIES)

DOUBLE 4" YELLOW (TYP.)  
 4" SOLID WHITE (TYP.)  
 4" BROKEN WHITE (TYP.)

## TYPICAL INTERSECTION 2 THRU LANES PLUS LEFT TURN LANE, WITH CROSSWALK

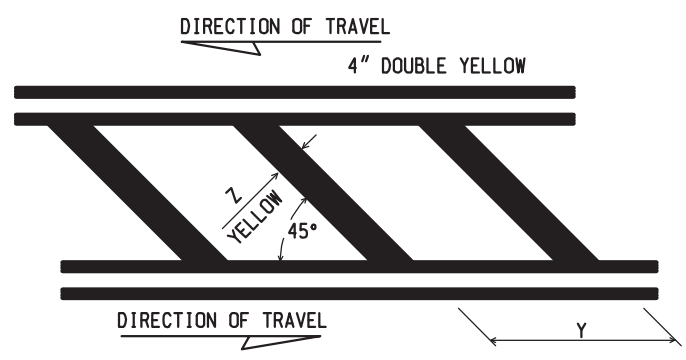

POSTED SPEED LIMIT (MPH)	"Y"	"Z"
	FT	IN
30 OR LESS	10	6
35	20	6
40	20	6
45	30	6
50 OR MORE	40	12

## DETAIL "A" ANGLED TRANSVERSE MARKING (OPTIONAL)

NOT TO SCALE File: PW: D/RD/TS/TYP/Signs/PM/mdot PAVE945A.dgn Rev. 03/15/07 MSH

**MDOT**  
 Michigan Department of Transportation

PREPARED BY  
 TRAFFIC AND SAFETY

DRAWN BY: SCT  
 CHECKED BY: JGM

*John C. Frieal*  
 ENGINEER OF DELIVERY

*John P. Poles*  
 ENGINEER OF DEVELOPMENT

7/10/07  
 FHWA APPROVAL DATE

BUREAU OF HIGHWAYS DELIVERY STANDARD PLAN FOR  
**INTERSECTION, STOP LINE  
 & CROSSWALK MARKINGS**

03/15/07 PLAN DATE	PAVE-945-A	SHEET 1 of 2
-----------------------	------------	-----------------

NOTE: THE ORIGINAL SIGNED COPY IS KEPT ON FILE AT THE MICHIGAN DEPARTMENT OF TRANSPORTATION.

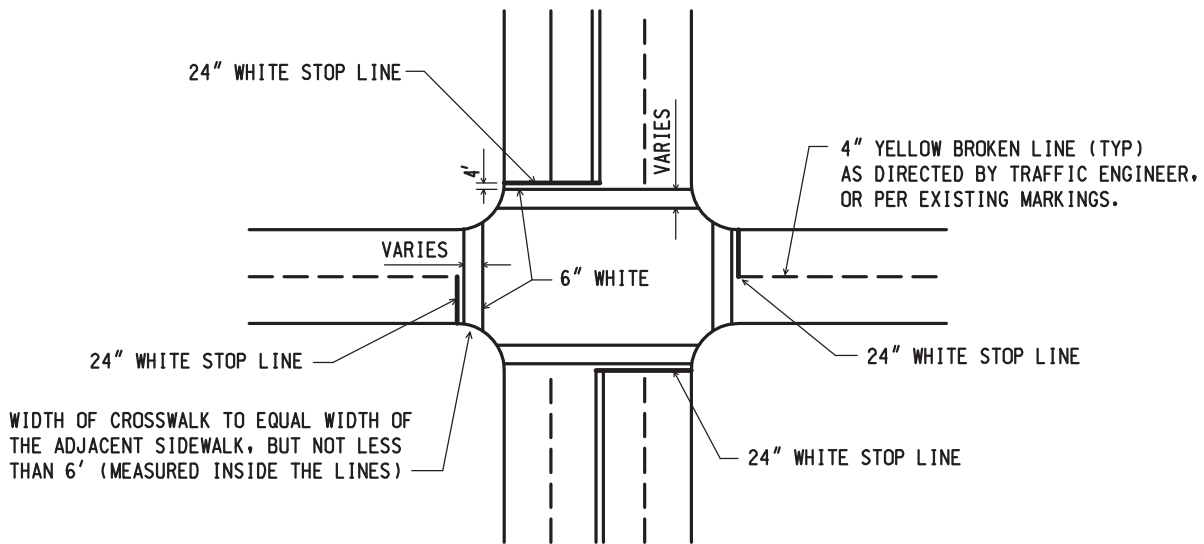

WIDTH OF CROSSWALK TO EQUAL WIDTH OF THE ADJACENT SIDEWALK, BUT NOT LESS THAN 6' (MEASURED INSIDE THE LINES)

**NOTES:**

1. When practical, crosswalk location should avoid conflict with drainage inlets.
2. When specified in plans or proposal, STOP legend shall be placed in advance of stop lines at stop controlled intersections a distance related to posted speed limit, as shown on pavement arrow and message details. See PAVE-900-Series sheet 3.
3. When noted in the plans or proposals STOP AHEAD legend shall be placed at the location of the stop ahead symbol sign.

**STOP LINES, CROSSWALKS AND  
DOUBLE CENTER LINE DETAILS**

NOT TO SCALE

MICHIGAN DEPARTMENT OF TRANSPORTATION BUREAU OF HIGHWAYS DELIVERY STANDARD PLAN	7/10/07 FHWA APPROVAL DATE	03/15/07 PLAN DATE	<b>PAVE-945-A</b>	SHEET 2 of 2
File: PW: D/RD/TS/TYP/Signs/PM/mdot PAVE945A.dgn Rev. 03/15/07 MSH				

NOTE: THE ORIGINAL SIGNED COPY IS KEPT ON FILE AT THE MICHIGAN DEPARTMENT OF TRANSPORTATION.

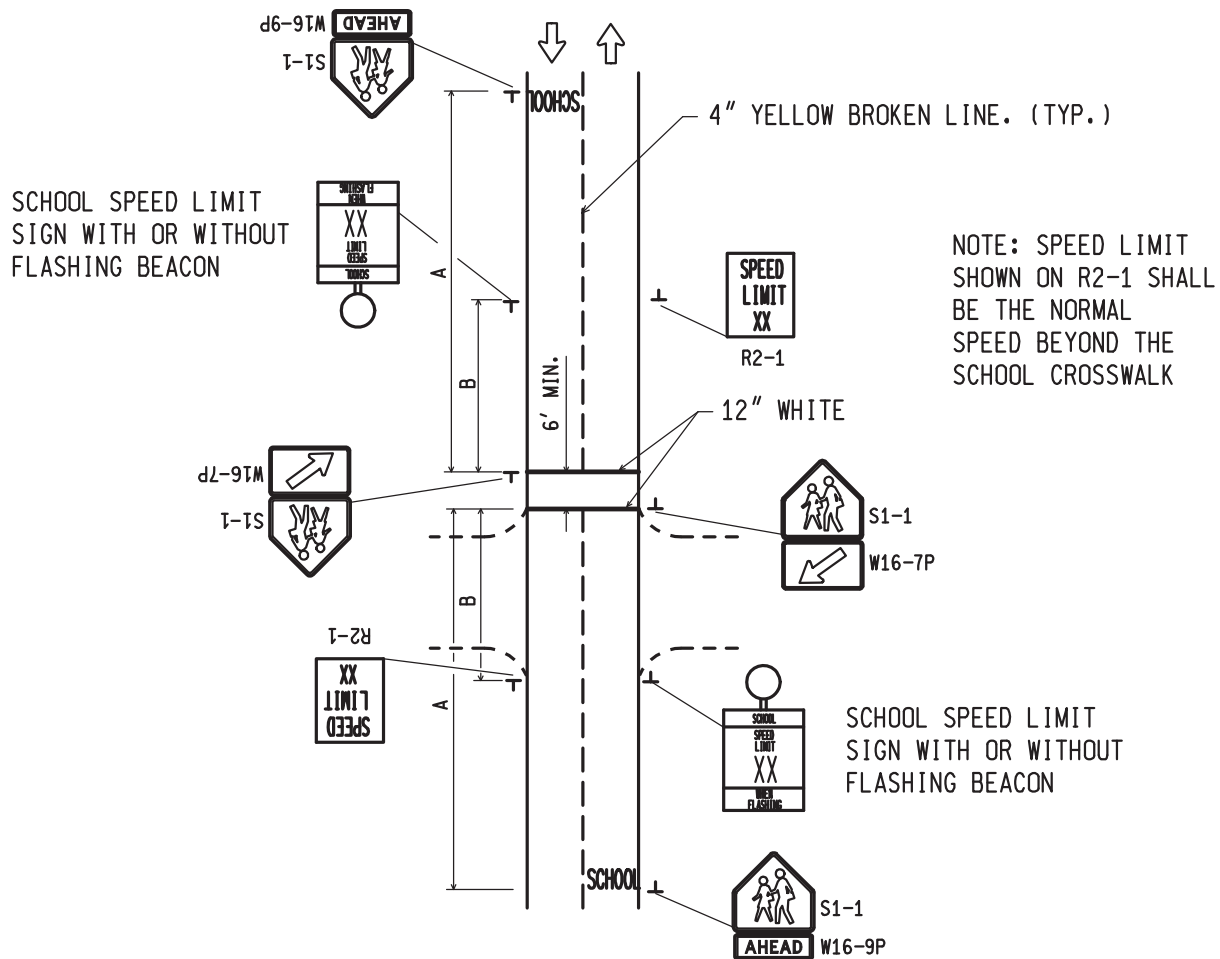

**TRAFFIC CONTROL DEVICES WITH OR WITHOUT FLASHING BEACON FOR REDUCED SPEED ZONE AT A SCHOOL CROSSWALK**

(NOT SIGNALIZED OR STOP CONTROLLED)  
 ( 2 LANES - 2 WAY TRAFFIC )  
 (MID BLOCK OR ON THRU STREET AT AN INTERSECTION)

APPROACH SPEED (MPH) (NOT SCHOOL ZONE SPEED)	SUGGESTED DISTANCE	
	A (FT)	B (FT)
25-35	275	150
40-45	345	250
50-55	500	400

NOT TO SCALE

File: PW: D/RD/TS/TYP/Signs/PM/mdot PAVE960A.dgn Rev. 03/15/07 MSH

**MDOT**  
Michigan Department of Transportation

PREPARED BY  
TRAFFIC AND SAFETY

DRAWN BY: SCT  
CHECKED BY: JGM

*John C. Frieal*  
ENGINEER OF DELIVERY

*John P. Poles*  
ENGINEER OF DEVELOPMENT

7/10/07  
FHWA APPROVAL DATE

BUREAU OF HIGHWAYS DELIVERY STANDARD PLAN FOR

**SCHOOL SIGNS AND MARKINGS**

03/15/07  
PLAN DATE

**PAVE-960-A**

SHEET  
1 of 3

NOTE: THE ORIGINAL SIGNED COPY IS KEPT ON FILE AT THE MICHIGAN DEPARTMENT OF TRANSPORTATION.

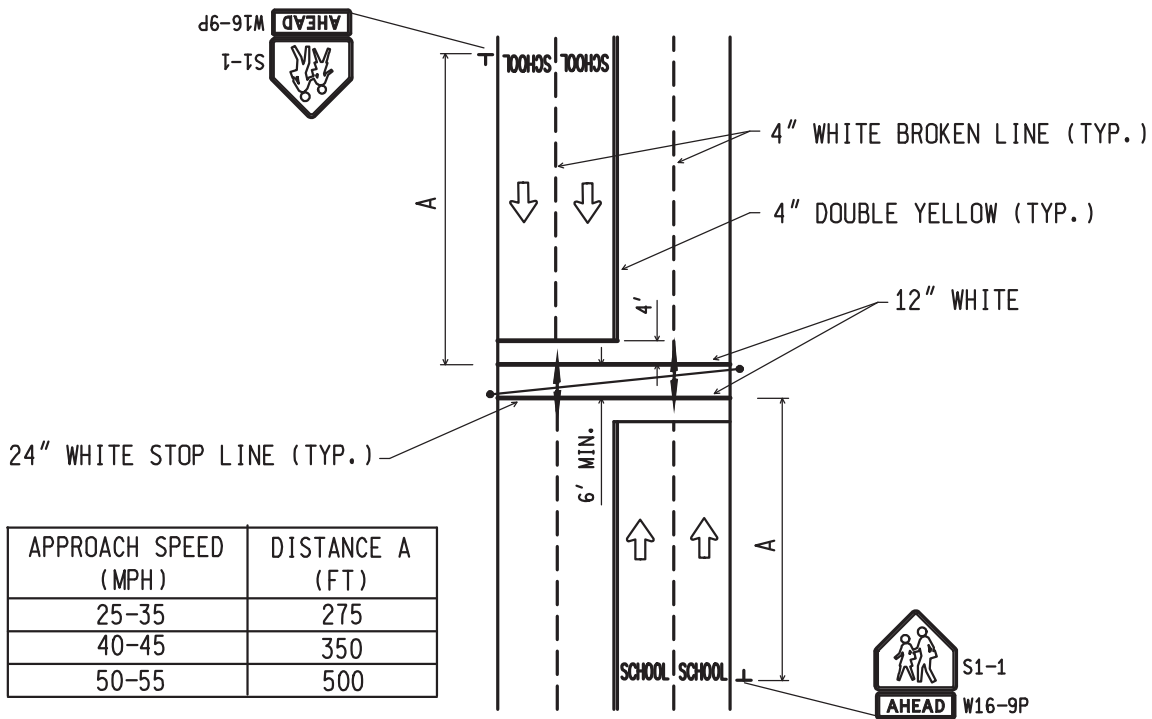

APPROACH SPEED (MPH)	DISTANCE A (FT)
25-35	275
40-45	350
50-55	500

### SIGNALIZED MID BLOCK SCHOOL CROSSWALK

NOTE: Special speed restrictions are not normally applicable in these cases.

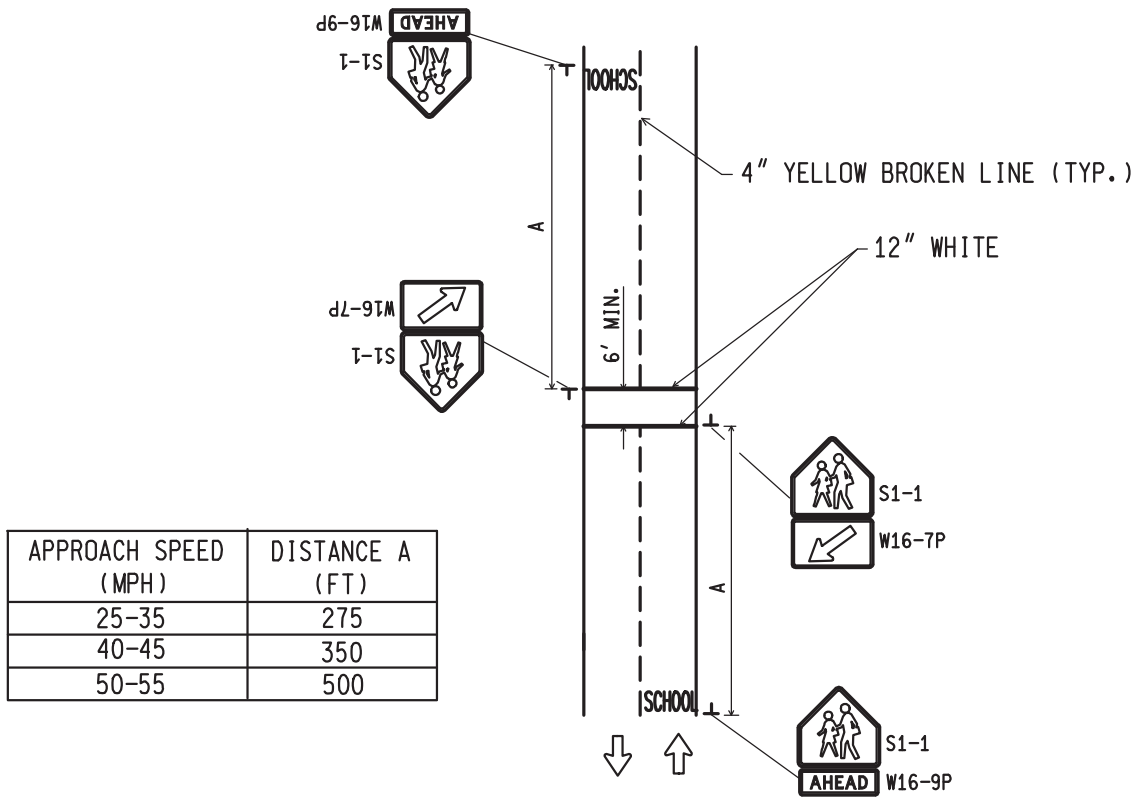

APPROACH SPEED (MPH)	DISTANCE A (FT)
25-35	275
40-45	350
50-55	500

### TRAFFIC CONTROL DEVICES FOR A SCHOOL CROSSWALK WITHOUT A SPEED REDUCTION

( 2 LANES - 2 WAY TRAFFIC )

NOT TO SCALE

MICHIGAN DEPARTMENT OF TRANSPORTATION BUREAU OF HIGHWAYS DELIVERY STANDARD PLAN	7/10/07 FHWA APPROVAL DATE	03/15/07 PLAN DATE	PAVE-960-A	SHEET 2 of 3
File: PW: D/RD/TS/TYP/Signs/PM/mdot_PAVE960A.dgn Rev. 03/15/07 MSH				

NOTE: THE ORIGINAL SIGNED COPY IS KEPT ON FILE AT THE MICHIGAN DEPARTMENT OF TRANSPORTATION.

**SINGLE LANE APPROACH**

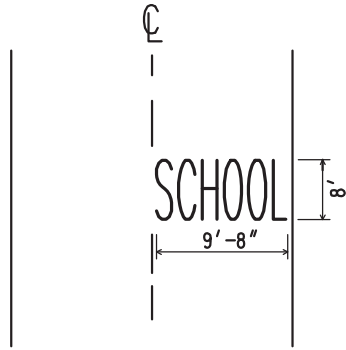

Pavement marking should not extend over into opposing lane.

**TWO LANE APPROACH**

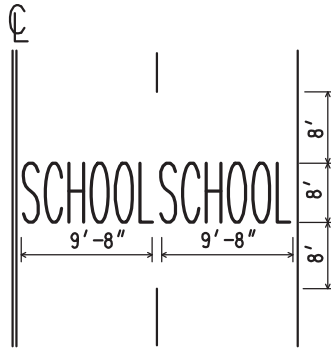

Single "SCHOOL" pavement marking may be used as an option. See scheme 2.

**MULTI LANE APPROACH  
(THREE OR MORE)**

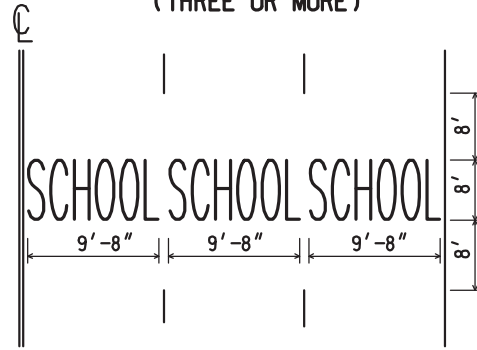

Individual 9'-8" markings for each lane omit legend in left turn or exclusive right turn lanes.

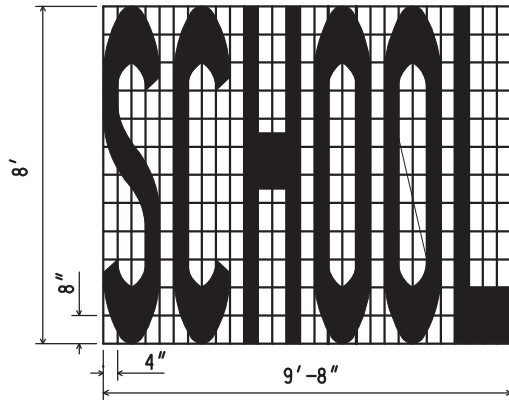

SINGLE - LANE PAVEMENT MARKING  
78 SFT.

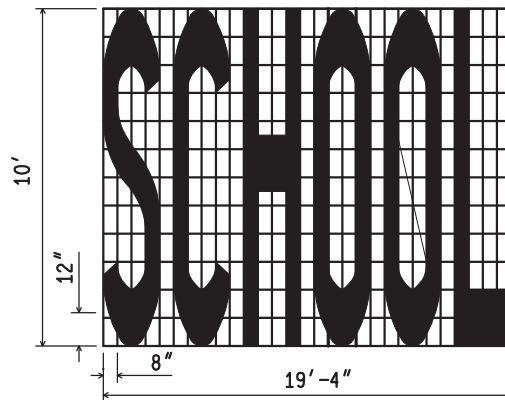

TWO - LANE PAVEMENT MARKING  
194 SFT.  
(OPTIONAL)

**NOTES:**

**SCHEME 1**

**SCHEME 2**

1. On roadways with multiple lanes in each direction, overhead installation of either the S1-1 or the school speed limit sign (with or without flashing beacon) may be warranted, based on the results of a detailed engineering and traffic study.
2. A and B distances shall be increased by adding the intersecting street width (curb returns included) to dimensions given in the table.
3. The A distance shall not exceed 700 ft.
4. School advance signs (S1-1) and pavement markings should be located at a distance "A" as shown on the table on sheet 2 of PAVE-910-Series or if a school building is located at the intersection, the signs and markings shall be placed not less than 150 ft nor more than 700 ft in advance of the school property line.
5. Pavement lane line markings (passing, no passing zone) as per existing markings or as directed by the Traffic Engineer.
6. Refer to PAVE-945-Series or PAVE-950-Series for stop line and crosswalk marking detail.
7. All school signs (S1-1, W16-7P, and W16-9P) shall be Fluorescent Yellow Green.

NOT TO SCALE

MICHIGAN DEPARTMENT OF TRANSPORTATION BUREAU OF HIGHWAYS DELIVERY STANDARD PLAN	7/10/07 FHWA APPROVAL DATE	03/15/07 PLAN DATE	PAVE-960-A	SHEET 3 of 3
File: PW: D/RD/TS/TYP/Signs/PM/mdot_PAVE960A.dgn Rev. 03/15/07 MSH				

NOTE: THE ORIGINAL SIGNED COPY IS KEPT ON FILE AT THE MICHIGAN DEPARTMENT OF TRANSPORTATION.

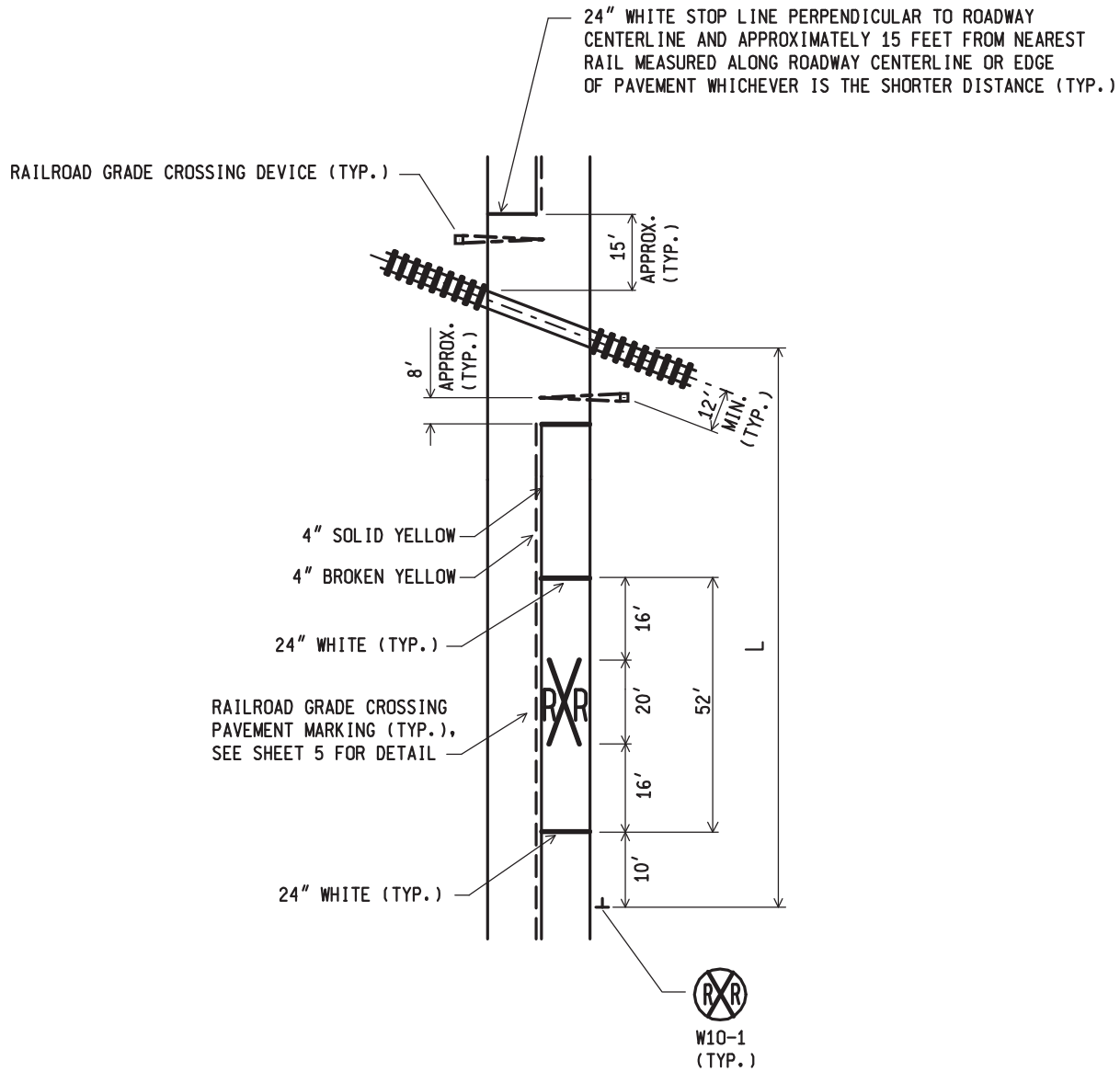

POSTED SPEED (MPH)	DISTANCE "L" (FT)
35 AND BELOW	250
40-45	400
50-55	550
60 AND ABOVE	750

## RAILROAD CROSSING AT TWO LANE ROADWAY

(ACUTE TRACK/ROADWAY ANGLE)

NOT TO SCALE

File: PW: D/RD/TS/TYP/Signs/PM/mdot PAVE965.dgn Rev. 03/15/07 am

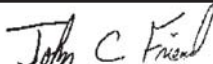
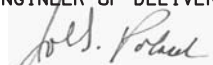
 PREPARED BY TRAFFIC AND SAFETY	 ENGINEER OF DELIVERY	BUREAU OF HIGHWAYS DELIVERY STANDARD PLAN FOR <b>RAILROAD GRADE CROSSING          PAVEMENT MARKINGS</b>		
	 ENGINEER OF DEVELOPMENT	7/10/07 FHWA APPROVAL DATE	03/15/07 PLAN DATE	PAVE-965-A

NOTE: THE ORIGINAL SIGNED COPY IS KEPT ON FILE AT THE MICHIGAN DEPARTMENT OF TRANSPORTATION.



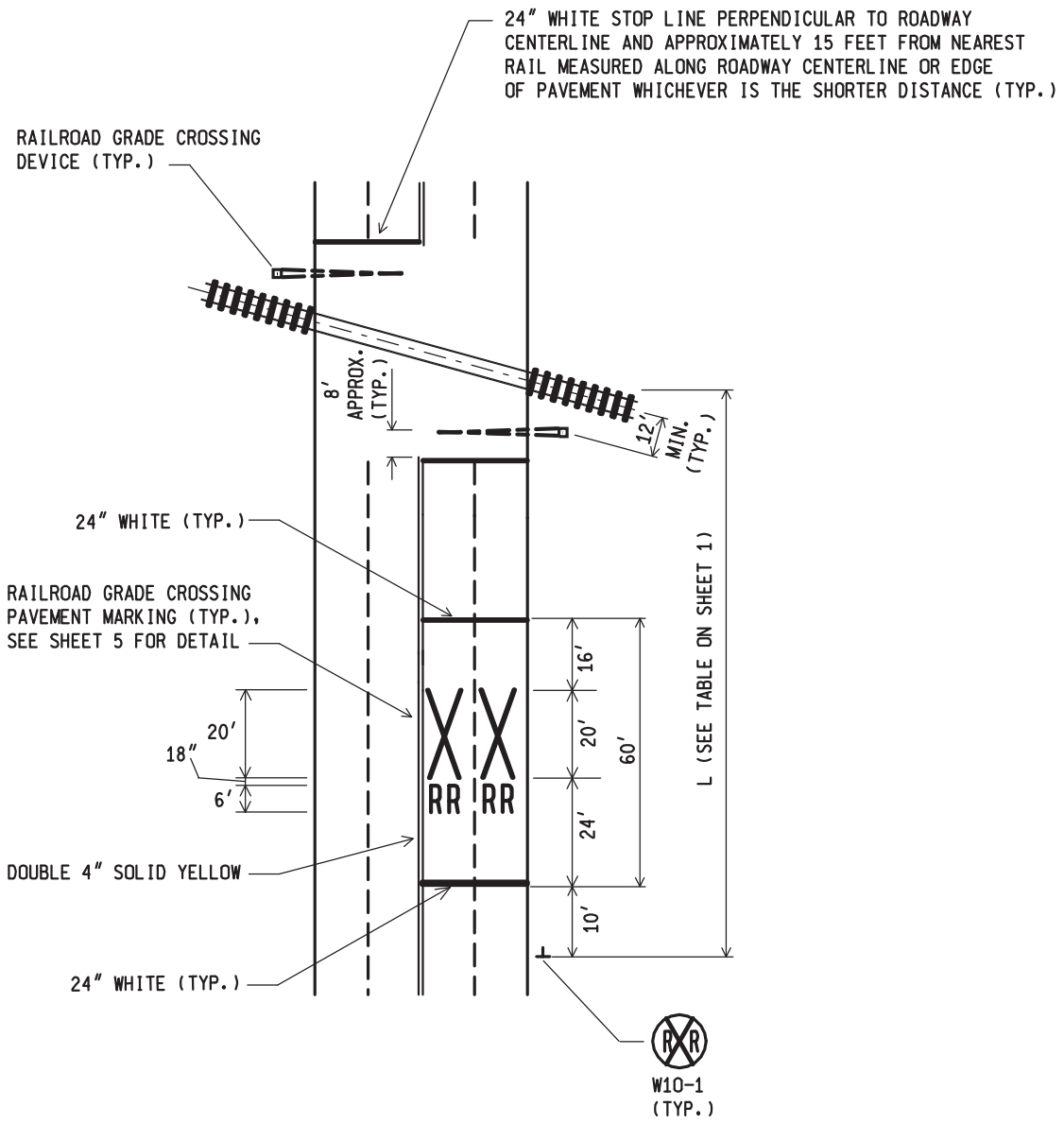

## RAILROAD CROSSING AT MULTI LANE ROADWAY

(ACUTE TRACK/ROADWAY ANGLE)  
(ALTERNATE MARKINGS SHOWN)

NOT TO SCALE

MICHIGAN DEPARTMENT OF TRANSPORTATION  
BUREAU OF HIGHWAYS DELIVERY STANDARD PLAN

7/10/07  
FHWA APPROVAL DATE

03/15/07  
PLAN DATE

PAVE-965-A

SHEET  
2 of 5

File: PW: D/RD/TS/TYP/Signs/PM/mdot PAVE965.dgn Rev. 03/15/07 am

NOTE: THE ORIGINAL SIGNED COPY IS KEPT ON FILE AT THE MICHIGAN DEPARTMENT OF TRANSPORTATION.

24" WHITE STOP LINE PERPENDICULAR TO ROADWAY CENTERLINE AND APPROXIMATELY 15 FEET FROM NEAREST RAIL MEASURED ALONG ROADWAY CENTERLINE OR EDGE OF PAVEMENT WHICHEVER IS THE SHORTER DISTANCE (TYP.)

RAILROAD GRADE CROSSING DEVICE (TYP.)

\* MEASURED FROM INTERSECTION SPRING POINT TO THE NEAREST RAIL

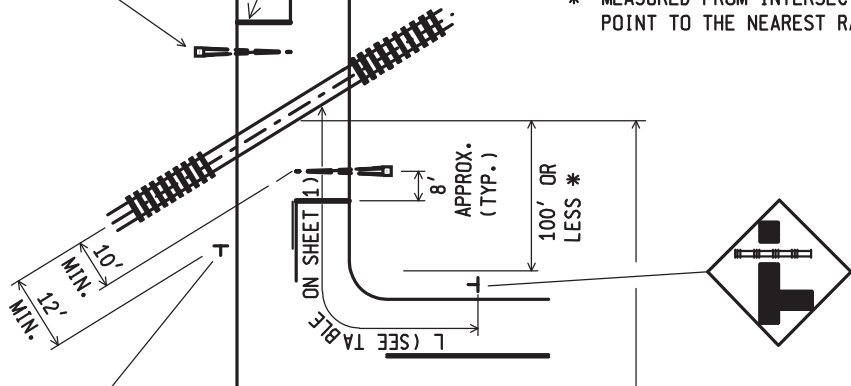

W10-2, W10-3 OR W10-4  
SEE SHEET 5, NOTE 4.  
SEE ALSO TRAFFIC AND  
SAFETY NOTE 148-Series.

**DO NOT STOP ON TRACKS**  
R8-8 \*\*  
(OPTIONAL)

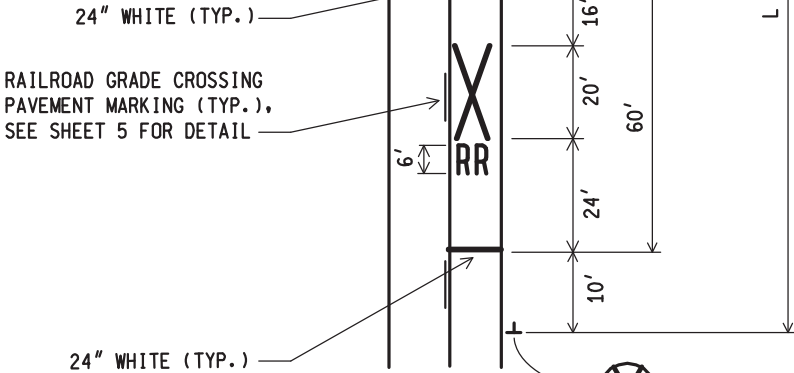

\*\* FOR USE NEAR SIGNALIZED OR STOP CONTROLLED INTERSECTIONS. R8-8 MAY ALSO BE PLACED ON THE APPROACH TO GRADE CROSSING AT 12 FEET PERPENDICULAR DISTANCE FROM TRACK C. SEE ALSO TRAFFIC AND SAFETY NOTE 148-Series.

**RAILROAD CROSSING WITH INTERSECTING ROADWAY**  
**LESS THAN 100 FEET FROM TRACK**  
(OBTUSE TRACK/ROADWAY ANGLE)  
(ALTERNATE MARKINGS SHOWN)

NOT TO SCALE

MICHIGAN DEPARTMENT OF TRANSPORTATION BUREAU OF HIGHWAYS DELIVERY STANDARD PLAN	7/10/07 FHWA APPROVAL DATE	03/15/07 PLAN DATE	PAVE-965-A	SHEET 3 of 5
File: PW: D/RD/TS/TYP/Signs/PM/mdot PAVE965.dgn Rev. 03/15/07 am				

NOTE: THE ORIGINAL SIGNED COPY IS KEPT ON FILE AT THE MICHIGAN DEPARTMENT OF TRANSPORTATION.

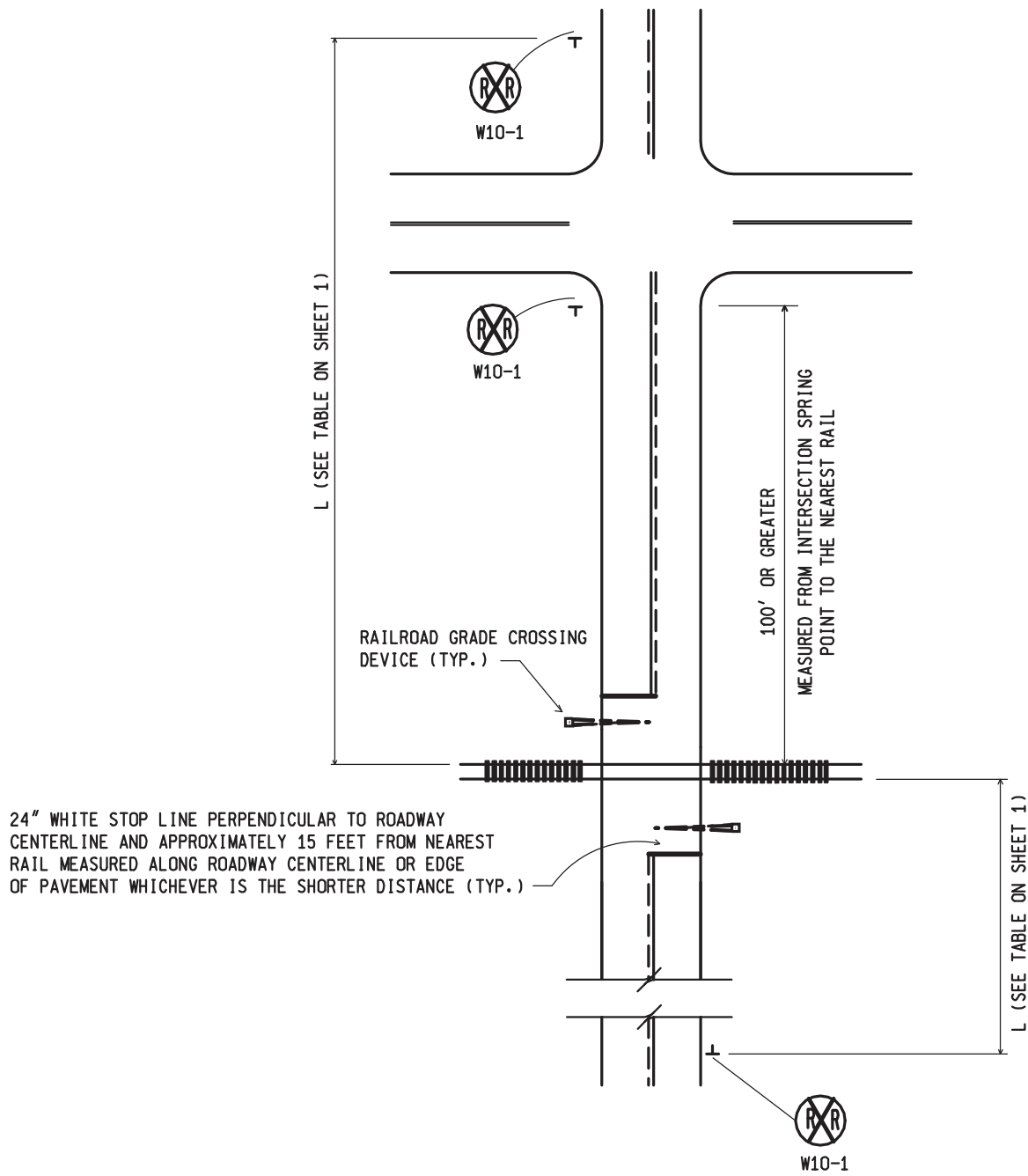

**RAILROAD CROSSING WITH INTERSECTING ROADWAY**  
**GREATER THAN 100 FEET FROM TRACK**  
**(90° TRACK/ROADWAY ANGLE)**

**NOTES:**

1. Pavement marking "R X R" not shown for simplicity, but shall be installed as shown on sheets 1 and 3, 10 foot beyond both W10-1 signs. Initial 10-1 shall be located sufficiently in advance of crossroad to avoid placing "R X R" markings within the intersection.
2. Vehicular right-of-way at intersection not shown. W10-1 sign placement would be the same regardless of which roadway has right-of-way at intersection.

NOT TO SCALE

MICHIGAN DEPARTMENT OF TRANSPORTATION BUREAU OF HIGHWAYS DELIVERY STANDARD PLAN	7/10/07 FHWA APPROVAL DATE	03/15/07 PLAN DATE	<h2 style="margin: 0;">PAVE-965-A</h2>	SHEET 4 of 5
File: PW: D/RD/TS/TYP/Signs/PM/mdot PAVE965.dgn Rev. 03/15/07 am				

NOTE: THE ORIGINAL SIGNED COPY IS KEPT ON FILE AT THE MICHIGAN DEPARTMENT OF TRANSPORTATION.

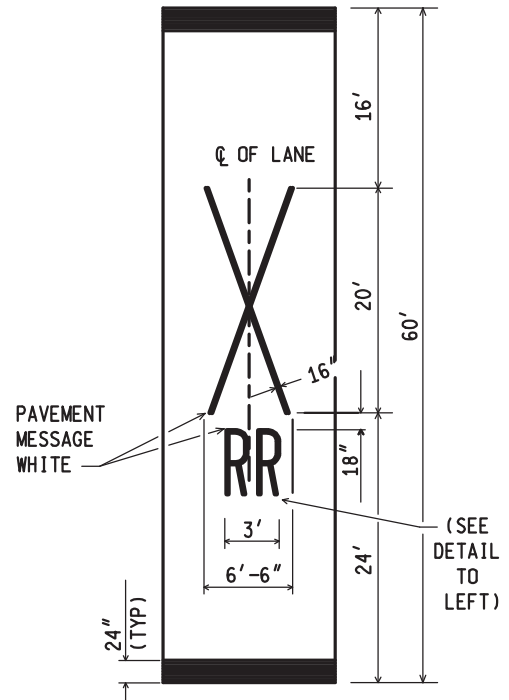
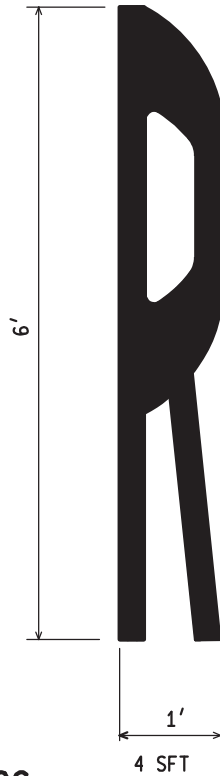
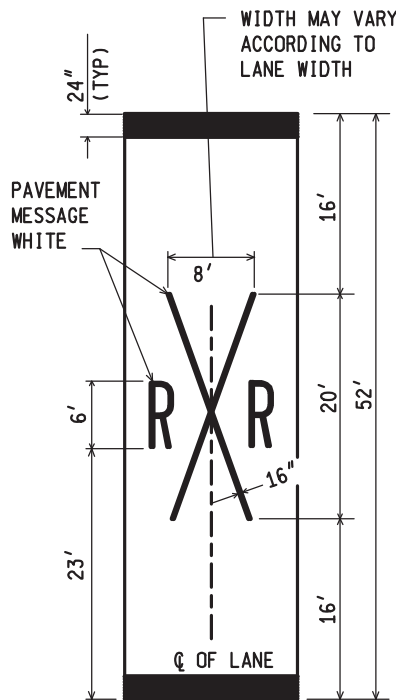

**CONVENTIONAL MARKINGS**

**ALTERNATE MARKINGS**

**NOTES:**

1. This document shows active grade crossing devices on two lane and multi-lane roadways. If passive grade crossing devices (crossbucks) are present, the stop bar should be located at the crossbuck, but no closer than 15 feet from the nearest rail.
2. "R X R" pavement markings can be omitted for exclusive right turn lane locations. "R X R" pavement markings are optional for center lane left turn only lanes.
3. On divided roadways, additional warning devices may be installed in the median.
4. At locations where an intersecting crossroad is within 100 feet of the grade crossing (measured from intersection radius to nearest rail), a W10-2, W10-3, or W10-4 sign shall be erected at a distance "L" (see table on sheet 1) measured along the centerline of the far right lane as shown.
5. The alternate pavement markings may be specified at any grade crossing, but their use is particularly advantageous on roadways subjected to high traffic volumes, since they are designed to minimize the amount of markings applied in the wheel tracks, thereby extending marking life. Identical types of markings shall be installed on both roadway approaches.
6. Unless specifically stated otherwise on contract plans or in the proposal, payment for the 24 inch (typ.) transverse markings immediately above and below the "R X R" marking will be paid for separately.

NOT TO SCALE

MICHIGAN DEPARTMENT OF TRANSPORTATION BUREAU OF HIGHWAYS DELIVERY STANDARD PLAN	7/10/07 FHWA APPROVAL DATE	03/15/07 PLAN DATE	PAVE-965-A	SHEET 5 of 5
File: PW: D/RD/TS/TYP/Signs/PM/mdot PAVE965.dgn Rev. 03/15/07 am				

NOTE: THE ORIGINAL SIGNED COPY IS KEPT ON FILE AT THE MICHIGAN DEPARTMENT OF TRANSPORTATION.

**SPECIAL PROVISION  
FOR  
MAINTAINING TRAFFIC**

General:

Traffic shall be maintained throughout the project in accordance with Sections 104.11 and Section 812 of the 2012 Standard Specifications for Construction. This includes any supplemental specifications and as herein specified.

The contractor shall coordinate this work with other contractors performing work within common or adjoining areas. The contractor shall avoid conflicts in maintaining traffic operations, signing, and orderly progress of other contract work.

Construction Influence Area (CIA)

The CIA shall include the right-of-way of all roads scheduled for application of pavement markings under the terms of this proposal.

Traffic Restrictions

Application of pavement markings may be allowed at night at the direction of the Engineer. The work shall be suspended during the time when traffic is being unduly hampered or delayed by the work in progress or as determined by the Engineer.

The contractor shall furnish and place all necessary warning and directional devices to maintain traffic. The contractor shall also provide protection to the uncured markings as may be needed until traffic can cross the uncured line without damage. Traffic shall be allowed to keep moving at all times and the striping equipment shall be operated in a manner that will not make it necessary to cross the uncured line.

Traffic Control Devices

All traffic control devices and their placement shall be in accordance with the requirements in the 2011 Michigan Manual of Uniform Traffic Control Devices (MMUTCD) and as specified in the plans and/or proposal.

The paint machine vehicle shall be equipped with a lighted arrow Type A or B. A trailing vehicle equipped with a lighted arrow Type A or B shall be used for coning and additional traffic control. Cones shall be placed at a maximum of fifty (50) foot intervals. Spacing shall have a minimum height of eighteen (18) inches and be of an approved type. A 6 foot x 3 foot sign with six-inch minimum legend "Pavement Marking Ahead" shall be mounted on the trailing vehicle. Refer to earlier section for the specifications for this sign. The cone pickup vehicle shall have a roof mounted lighted arrow board. The arrow board shall have a minimum twelve (12) lamp system and a minimum 5 foot x 2 foot size.

All traffic control items needed to maintain traffic during the painting operation shall be considered incidental to the items of pavement marking.

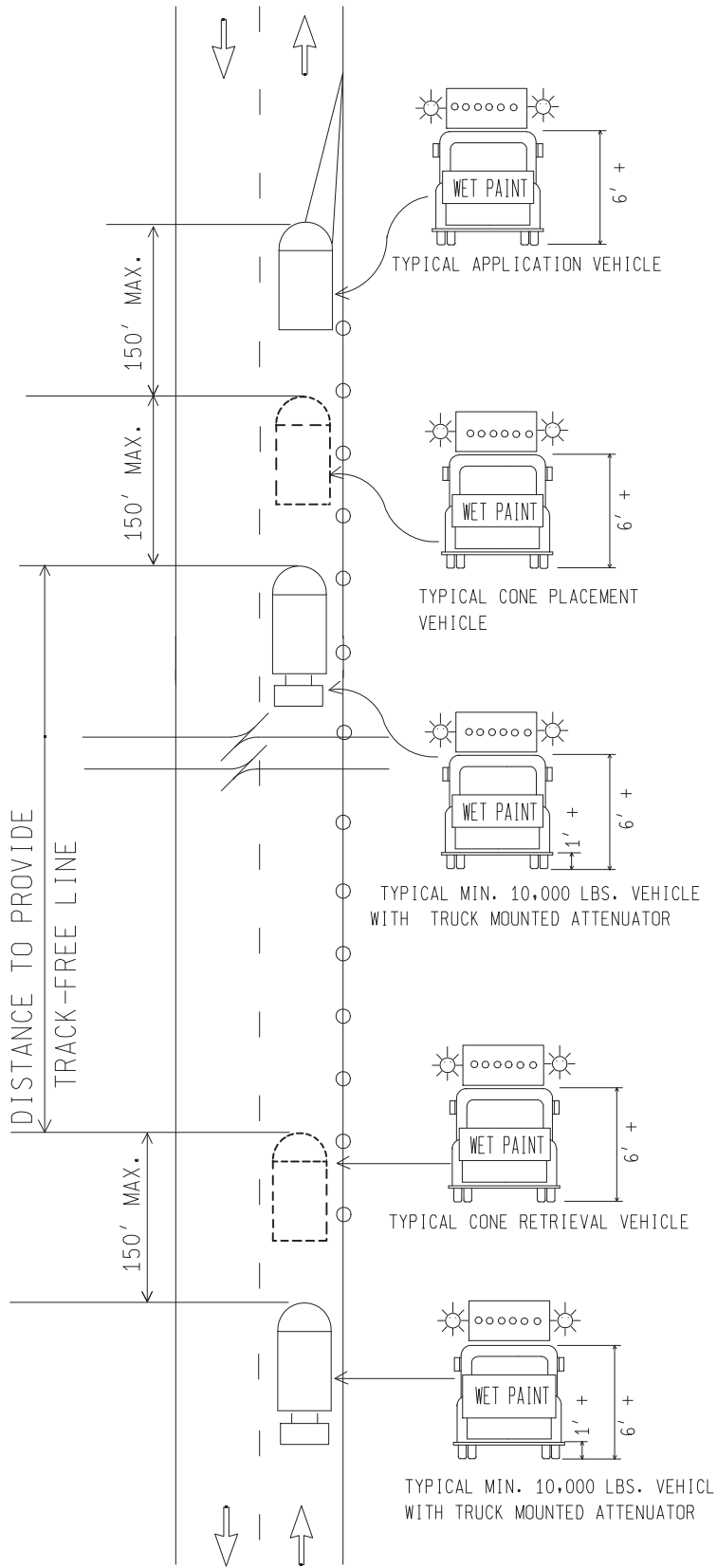

1. ALL VEHICLES SHALL BE EQUIPPED WITH:
  - a. TWO ROTATING YELLOW BEACONS OR STROBES VISIBLE FROM ANY APPROACH ANGLE
  - b. TYPE B OR C FLASHING ARROW PANEL AS SHOWN
  - c. "WET PAINT" SIGN AS SHOWN

2. ATTENUATED VEHICLE(S) SHALL WEIGH AT LEAST 10,000 LBS. AND BE LOCATED AS SHOWN.

3. BOTH THE CONE PLACEMENT AND CONE RETRIEVAL VEHICLES MAY BE INCORPORATED INTO THE VEHICLE EQUIPPED WITH THE TRUCK MOUNTED ATTENUATOR. CONES SHOULD BE PLACED 100' APART.

6. DASHED LINE DENOTES OPTIONAL VEHICLE.

13. ON ROADWAYS WITH TWO OR MORE LANES IN EACH DIRECTION, THE ILLUSTRATED CONVOY IS APPLICABLE EXCEPT LEFT DIRECTIONAL FLASHING ARROW PANEL SHALL BE USED.

17. CENTER LINE MAY NOT BE STRIPED AT THE SAME TIME AS THE EDGELINE.

20. REFER TO PMC22e FOR ADDITIONAL CONVOY SIGNING REQUIREMENTS

22. FOR RAMPS AND NON-FREEWAY WORK - USE MIN 18 INCH CONES FOR LINE PROTECTION.

 TRAFFIC AND SAFETY DIVISION	PAVEMENT MARKING CONVOY WATERBORNE PAINT TYPICAL FOR NON-FREEWAY EDGELINES WITH CONES (ALL REGIONS)	
	File: pw:rd/tr/typ/final/pave markings/pmc10e Drawn by: ABG	Rev. Date: 04/30/2012 Imf

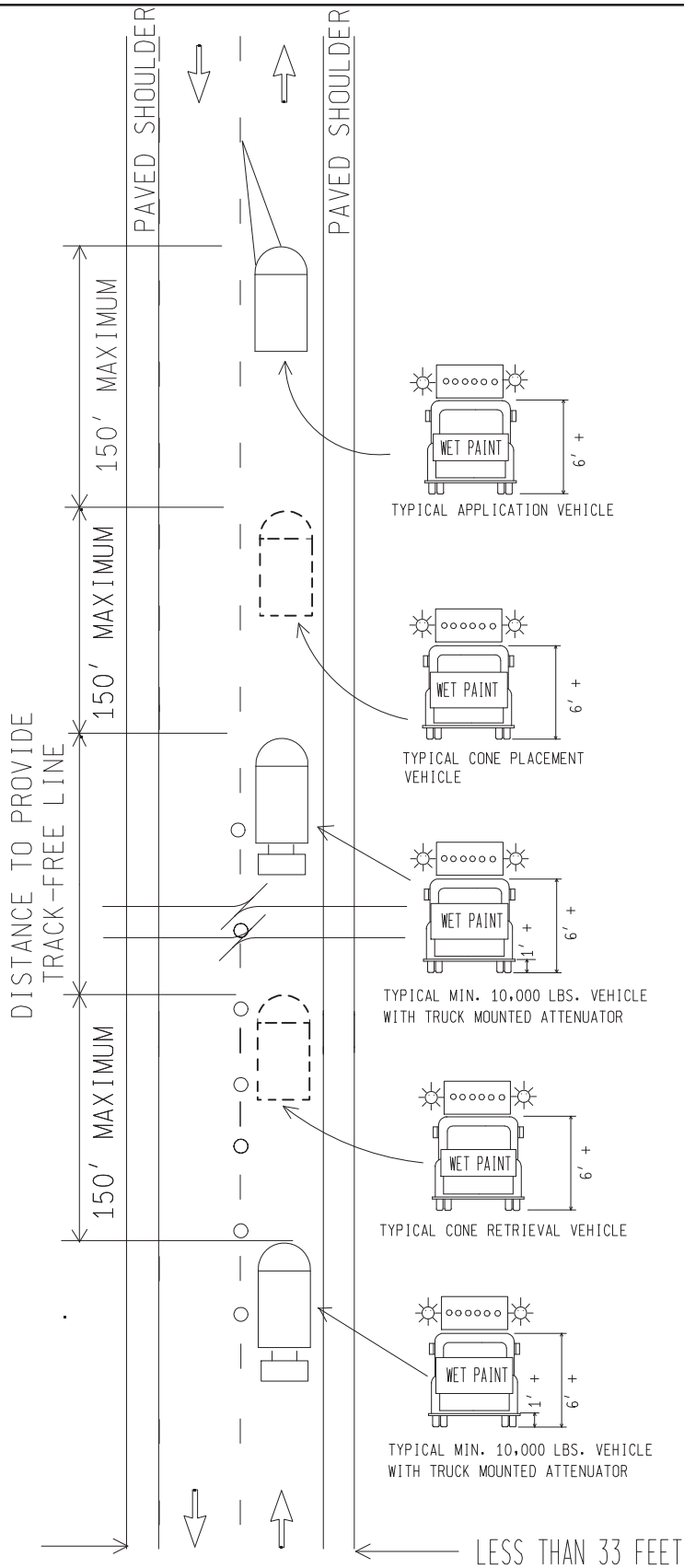

1. ALL VEHICLES SHALL BE EQUIPPED WITH:
  - a. TWO ROTATING YELLOW BEACONS OR STROBES VISIBLE FROM ANY APPROACH ANGLE
  - b. TYPE B OR C FLASHING ARROW PANEL AS SHOWN
  - c. "WET PAINT" SIGN AS SHOWN

2. ATTENUATED VEHICLE(S) SHALL WEIGH AT LEAST 10,000 LBS. AND BE LOCATED AS SHOWN.

3. BOTH THE CONE PLACEMENT AND CONE RETRIEVAL VEHICLES MAY BE INCORPORATED INTO THE VEHICLE EQUIPPED WITH THE TRUCK MOUNTED ATTENUATOR.

6. DASHED LINE DENOTES OPTIONAL VEHICLE.

15. WHERE SHOULDERS ARE NARROW AND INSUFFICIENT WIDTH EXISTS TO ALLOW PASSING ON THE RIGHT, THE CONVOY SHALL CEASE OPERATION AND PULL OFF THE ROADWAY TO ALLOW QUEUED TRAFFIC TO PASS AT REASONABLE INTERVALS.

17. CENTER LINE MAY NOT BE STRIPED AT THE SAME TIME AS THE EDGELINE.

20. REFER TO PMC22e FOR ADDITIONAL CONVOY SIGNING REQUIREMENTS

22. FOR RAMP AND NON-FREEWAY WORK - USE MIN 18 INCH CONES FOR LINE PROTECTION.

<p>TRAFFIC AND SAFETY DIVISION</p>	<p>PAVEMENT MARKING CONVOY WATERBORNE PAINT TYPICAL FOR 2-LANE 2-WAY ROADWAY CENTERLINE (ALL REGIONS)</p>	
	<p>File: pw:rd/tr/typ/final/pave markings/pmc11e Drawn by: ABG</p>	<p>Rev. Date: 04/30/2012 Imf</p>

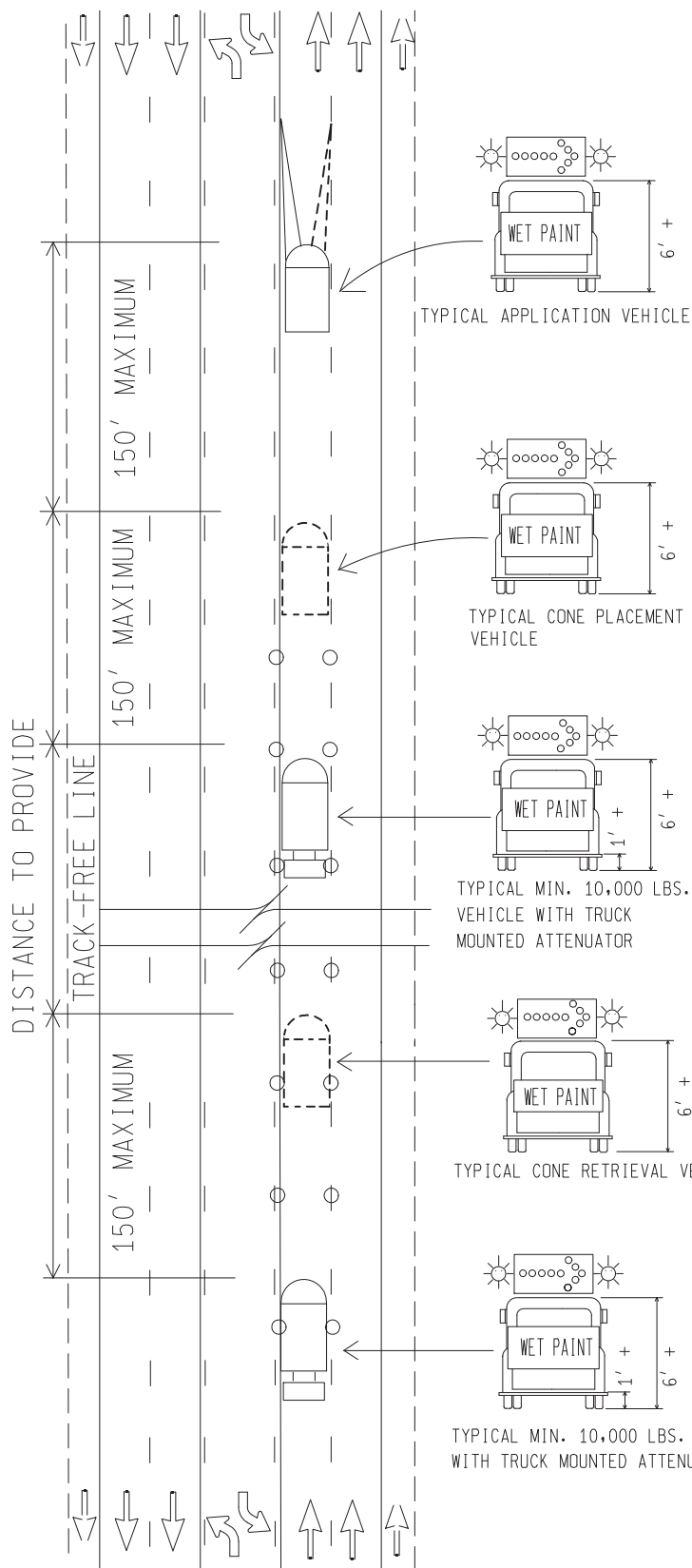

1. ALL VEHICLES SHALL BE EQUIPPED WITH:
  - a. TWO ROTATING YELLOW BEACONS OR STROBES VISIBLE FROM ANY APPROACH ANGLE
  - b. TYPE B OR C FLASHING ARROW PANEL AS SHOWN
  - c. "WET PAINT" SIGN AS SHOWN

2. ATTENUATED VEHICLE(S) SHALL WEIGH AT LEAST 10,000 LBS. AND BE LOCATED AS SHOWN.

3. BOTH THE CONE PLACEMENT AND CONE RETRIEVAL VEHICLES MAY BE INCORPORATED INTO THE VEHICLE EQUIPPED WITH THE TRUCK MOUNTED ATTENUATOR. CONES SHOULD BE PLACED 100' APART.

6. DASHED LINE DENOTES OPTIONAL VEHICLE.

18. LANE LINE MAY NOT BE APPLIED AT THE SAME TIME AS THE CENTER LINE IN 3 LANE NON-FREEWAY SECTIONS.

20. REFER TO PMC22e FOR ADDITIONAL CONVOY SIGNING REQUIREMENTS.

22. FOR RAMPS AND NON-FREEWAY WORK - USE MIN 18 INCH CONES FOR LINE PROTECTION.

 TRAFFIC AND SAFETY DIVISION	PAVEMENT MARKING CONVOY WATERBORNE PAINT TYPICALS FOR CENTER LANE FOR LEFT TURN AND NON-FREEWAY LANELINES (ALL REGIONS)	
	File: pw:rd/tr/typ/final/pave markings/pmc13e Drawn by: ABG	Rev. Date: 04/30/2012 lmf



# PAVEMENT MARKING SIGNS



END MAY BE SUBSTITUTED FOR BEGIN.

BEGIN/END CONVOY SIGNS REQUIRED ON FIRST/LAST VEHICLE, RESPECTIVELY.

NOTE: BEGIN/END CONVOY SIGNS SHALL HAVE BLACK LETTERS ON A REFLECTIVE WHITE BACKGROUND PER SECTION 9.22 OF THE STANDARD SPECIFICATIONS FOR CONSTRUCTION

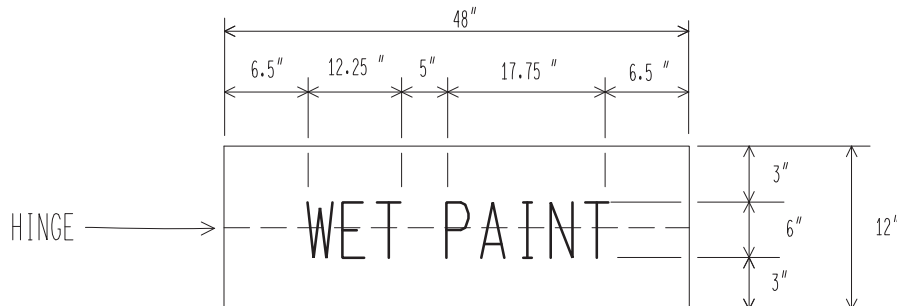

HORIZONTAL HINGE TO PERMIT FOLDING TOP HALF OF SIGN DOWN WHEN MARKING OPERATIONS ARE NOT IN PROGRESS. POSITION HINGE SO AS TO MINIMIZE SPLITTING HORIZONTAL ELEMENTS OF "E" AND "A".

HINGED SIGN REQUIRED ON FRONT OF APPLICATION VEHICLE IN ALL PAINTING CONVOYS WHERE THERE IS ONCOMING TRAFFIC.

NOTE: WET PAINT SIGN SHALL HAVE BLACK LETTERS ON A REFLECTORIZED ORANGE BACKGROUND PER SECTION 9.22 OF THE STANDARD SPECIFICATIONS FOR CONSTRUCTION.



PAVEMENT MARKING CONVOY  
TYPICAL FOR  
SIGNS (ALL REGIONS)

File: pw: rd/tr/typ/final/pave markings/pmc22e  
Drawn by: ABG

Rev. Date: 04/30/2012 Imf

PMC22e

SHEET  
1 OF 1





PLACE THROUGHOUT WORK AREA AS INDICATED AND AFTER ALL MAJOR CROSSROADS IF PERMANENT SIGNS ARE NOT IN PLACE.

PLACE THIS SIGN ALONG WITH THE ADVANCE WORK ZONE SIGNING AS DEPICTED ON THE APPROPRIATE TYPICAL M0030a-M0080a.

PLACE THROUGHOUT WORK AREA AS INDICATED AND AFTER ALL MAJOR CROSSROADS IF PERMANENT SIGNS ARE NOT IN PLACE.

PLACE THIS SIGN ALONG WITH THE ADVANCE WORK ZONE SIGNING AS DEPICTED ON THE APPROPRIATE TYPICAL M0030a-M0080a.

**KEY**

-  TRAFFIC REGULATOR
-  CHANNELIZING DEVICES
-  LIGHTED ARROW PANEL (CAUTION MODE)
-  TRAFFIC FLOW
-  REFLECTS EXISTING SPEED LIMIT

SIGN = 200 ft± - TYPE B PLUS ADDITIONAL R2-1's THROUGHOUT WORK AREA

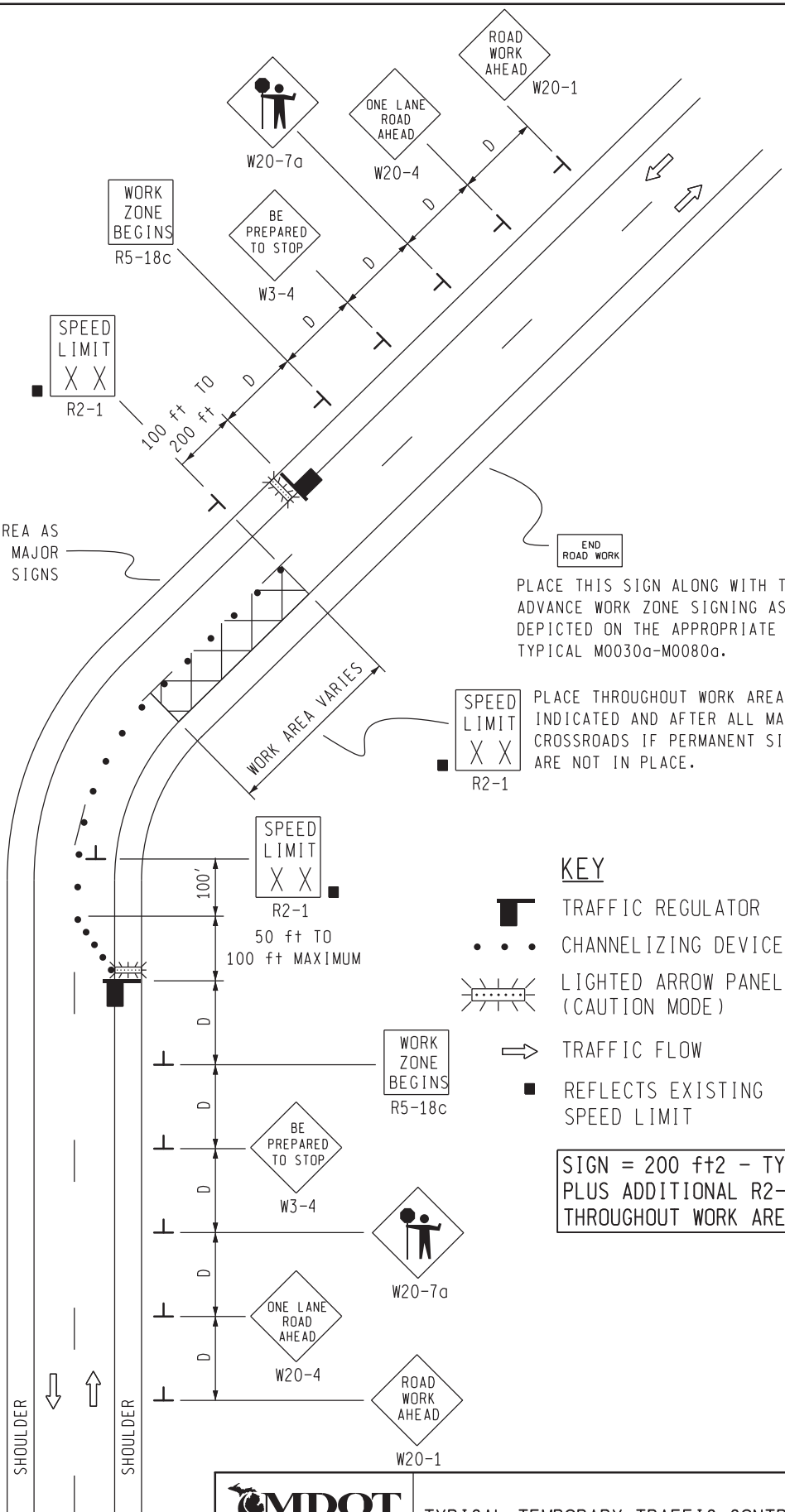

NOT TO SCALE

 Michigan Department of Transportation TRAFFIC AND SAFETY MAINTAINING TRAFFIC TYPICAL		TYPICAL TEMPORARY TRAFFIC CONTROL FOR A TWO-LANE TWO-WAY ROADWAY WHERE ONE LANE IS CLOSED UTILIZING TRAFFIC REGULATORS, NO SPEED REDUCTION	
DRAWN BY: CON:AE:djf CHECKED BY: BMM:CRB	OCTOBER 2011 PLAN DATE:	M0140a	SHEET 1 OF 2
FILE: PW RD/TS/Typicals/Signs/MT NON Fwy/M0140a.dgn REV. 10/04/2011			

## NOTES

- 1H. D = DISTANCE BETWEEN TRAFFIC CONTROL DEVICES AND LENGTH OF LONGITUDINAL BUFFERS  
SEE M0020a FOR "D" VALUES.
2. ALL NON-APPLICABLE SIGNING WITHIN THE CIA SHALL BE MODIFIED TO FIT CONDITIONS, COVERED OR REMOVED.
3. DISTANCES BETWEEN SIGNS, THE VALUES FOR WHICH ARE SHOWN IN TABLE D, ARE APPROXIMATE AND MAY NEED ADJUSTING AS DIRECTED BY THE ENGINEER.
- 3A. THE "WORK ZONE BEGINS" (R5-18c) SIGN SHALL BE USED ONLY IN THE INITIAL SIGNING SEQUENCE IN THE WORK ZONE. SUBSEQUENT SEQUENCES IN THE SAME WORK ZONE SHALL OMIT THIS SIGN AND THE QUANTITIES SHALL BE ADJUSTED APPROPRIATELY.
- 4A. THE MAXIMUM RECOMMENDED DISTANCE(S) BETWEEN CHANNELIZING DEVICES IN THE TAPER AREA(S) SHOULD BE 15 FEET AND SHOULD BE EQUAL IN FEET TO TWICE THE POSTED SPEED IN MILES PER HOUR IN THE PARALLEL AREA(S).
5. FOR OVERNIGHT CLOSURES, TYPE III BARRICADES SHALL BE LIGHTED.
6. WHEN CALLED FOR IN THE FHWA ACCEPTANCE LETTER FOR THE SIGN SYSTEM SELECTED, THE TYPE A WARNING FLASHER, SHOWN ON THE WARNING SIGNS, SHALL BE POSITIONED ON THE SIDE OF THE SIGN NEAREST THE ROADWAY.
7. ALL TEMPORARY SIGNS, TYPE III BARRICADES, THEIR SUPPORT SYSTEMS AND LIGHTING REQUIREMENTS SHALL MEET NCHRP 350 CRASHWORTHLY REQUIREMENTS STIPULATED IN THE CURRENT EDITION OF THE MICHIGAN MANUAL ON UNIFORM TRAFFIC CONTROL DEVICES, THE CURRENT EDITION OF THE STANDARD SPECIFICATIONS FOR CONSTRUCTION, THE STANDARD PLANS AND APPLICABLE SPECIAL PROVISIONS. ONLY DESIGNS AND MATERIALS APPROVED BY MDOT WILL BE ALLOWED.
9. ALL TRAFFIC REGULATORS SHALL BE PROPERLY TRAINED AND SUPERVISED.
- 9A. IN ANY OPERATION INVOLVING MORE THAN ONE TRAFFIC REGULATOR, ONE PERSON SHOULD BE DESIGNATED AS HEAD TRAFFIC REGULATOR.
10. ALL TRAFFIC REGULATORS' CONDUCT, THEIR EQUIPMENT, AND TRAFFIC REGULATING PROCEDURES SHALL CONFORM TO THE CURRENT EDITION OF THE MICHIGAN MANUAL OF UNIFORM TRAFFIC CONTROL DEVICES (MMUTCD) AND THE CURRENT EDITION OF THE MDOT HANDBOOK ENTITLED "TRAFFIC REGULATORS INSTRUCTION MANUAL."
11. WHEN TRAFFIC REGULATING IS ALLOWED DURING THE HOURS OF DARKNESS, APPROPRIATE LIGHTING SHALL BE PROVIDED TO SUFFICIENTLY ILLUMINATE THE TRAFFIC REGULATOR'S STATIONS.
- 12E. THE MAXIMUM DISTANCE BETWEEN THE TRAFFIC REGULATORS SHALL BE NO MORE THAN 2 MILES IN LENGTH UNLESS RESTRICTED FURTHER IN THE SPECIAL PROVISIONS FOR MAINTAINING TRAFFIC. ALL SEQUENCES OF MORE THAN 2 MILES IN LENGTH WILL REQUIRE WRITTEN PERMISSION FROM THE ENGINEER BEFORE PROCEEDING.
13. WHEN INTERSECTING ROADS OR SIGNIFICANT TRAFFIC GENERATORS (SHOPPING CENTERS, MOBILE HOME PARKS, ETC.) OCCUR WITHIN THE ONE-LANE TWO-WAY OPERATION, INTERMEDIATE TRAFFIC REGULATORS AND APPROPRIATE SIGNING SHALL BE PLACED AT THESE LOCATIONS.
14. ADDITIONAL SIGNING AND/OR ELONGATED SIGNING SEQUENCES SHOULD BE USED WHEN TRAFFIC VOLUMES ARE SIGNIFICANT ENOUGH TO CREATE BACKUPS BEYOND THE W3-4 SIGNS.
15. THE HAND HELD (PADDLE) SIGNS REQUIRED BY THE MMUTCD TO CONTROL TRAFFIC WILL BE PAID FOR AS PART OF FLAG CONTROL.
- 28E. THE TRAFFIC REGULATORS SHOULD BE POSITIONED AT OR NEAR THE SIDE OF THE ROAD SO THAT THEY ARE SEEN CLEARLY AT A MINIMUM DISTANCE OF 500 FEET. THIS MAY REQUIRE EXTENDING THE BEGINNING OF THE LANE CLOSURE TO OVERCOME VIEWING PROBLEMS CAUSED BY HILLS AND CURVES.

### SIGN SIZES

DIAMOND WARNING - 48" x 48"  
 R2-1 REGULATORY - 48" x 60"  
 R5-18c REGULATORY - 48" x 48"

NOT TO SCALE

 Michigan Department of Transportation TRAFFIC AND SAFETY MAINTAINING TRAFFIC TYPICAL	TYPICAL TEMPORARY TRAFFIC CONTROL FOR A TWO-LANE TWO-WAY ROADWAY WHERE ONE LANE IS CLOSED UTILIZING TRAFFIC REGULATORS, NO SPEED REDUCTION		
DRAWN BY: CON:AE:djf	OCTOBER 2011	M0140a	
CHECKED BY: BMM:CRB	PLAN DATE:		
FILE: PW RD/TS/Typicals/Signs/MT NON FWY/M0140a.dgn REV. 10/04/2011			

**SPECIAL PROVISION  
FOR  
GLASS BEADS FOR USE IN WATERBORNE PAVEMENT MARKING**

Description

These specifications cover glass beads for reflectorizing white and yellow paint markings on pavements by the drop-in methods on fresh paint stripes.

Detail Requirements

- a. General - The glass beads shall be of a transparent, lustrous, waterwhite glass composition designed to be highly resistant to traffic wear and to the effects of weathering. They shall be spherical in shape, and shall not include more than twenty-five (25%) percent, by count, of irregularly shaped particles. They shall be essentially free of dark particles and of particles showing milkiness, gas inclusions, pits and scratches.
- b. Gradation - The beads shall conform to the gradation requirements specified herein and will be tested in accordance with the Sieve Analysis of Glass Sphere, ASTM D 1214, using 50 to 100 gram samples obtained by means of a riffle sample splitter.

<u>Sieve No.</u>	<u>Total Percent Passing</u>
20	100
30	75-95
50	15-35
100	0-5

- c. Index of Refraction - The glass of which the beads are composed shall have an index of refraction of not less than 1.50 by the immersion method using tungsten light.
- d. Chemical Stability - After testing as described herein, the residual solution shall have an alkalinity number not greater than 2.0. The alkalinity number is defined as the number of ml of 0.1 N HCL required to reach the end point.

The test shall be conducted as follows:

Place 100 ml of distilled water in a 250 ml Erlenmeyer flask and bring to a boil.

Remove flask from heat source and introduce a ten (10) gram sample of glass beads.

Replace flask on heat source and boil gently for five minutes.

At the end of the five (5) minute boiling period, remove the beads from the water by filtering. Rinse the inside of the flask and beads with freshly distilled water and drain the washings into the original filtrate.

Stopper the flask containing the filtrate and allow to cool to room temperature and then titrate with 0.1 N HCL using phenolphthalein as the indicator.

Sampling and Testing

Requirements for testing are waived. The supplier shall submit a certification stating that the glass beads comply with the requirements of this specification. The right is reserved to sample and test as may be deemed necessary. Should the glass beads fail to comply with the specifications, the contractor shall be required to reapply with material meeting specifications at no cost to the county.

MICHIGAN  
DEPARTMENT OF TRANSPORTATION

SPECIAL PROVISION  
FOR  
**POLYUREA SURFACE PREPARATION WITH EXISTING POLYUREA MARKINGS**

PMK:MKB

1 of 1

APPR:MWB:CRB:08-02-16

**Delete the last paragraph and the included subsections from subsection 811.03.D.7, on page 595 of the Standard Specifications for Construction in its entirety and replace it with the following:**

Prepare existing HMA or PCC surfaces with existing polyurea markings and that may have oil drip areas, debris, or both, by scarifying the marking area using non-milling grinding teeth or shot blast.

**Add the following to the pay item list in subsection 811.04, on page 598 of the Standard Specifications for Construction:**

Scarification, for Polyurea Spec Mrkg ..... Square Foot

**Add the following after the last paragraph of subsection 811.04, on page 600 of the Standard Specifications for Construction:**

**E. Polyurea Surface Preparation.** The Engineer will measure the full preparation area for special markings based on the Pavement Marking Standard Plans.

MICHIGAN  
DEPARTMENT OF TRANSPORTATION

SPECIAL PROVISION  
FOR  
**PAVEMENT MARKINGS ON, CAPITAL PREVENTATIVE MAINTENANCE;  
COLD MILL AND ONE COURSE HOT MIX OVERLAY, AND  
ONE COURSE HOT MIX OVERLAY PROJECTS**

OFS:CGB

1 of 1

APPR:EMC:MKB:04-29-16

**a. Description.** This work consists of furnishing, installing and maintaining both temporary and permanent pavement markings on Capital Preventative Maintenance (CPM) cold mill and one course hot mix asphalt overlay, and one course hot mix asphalt overlay projects. Ensure all work is in accordance with sections 811, 812, 920 and 922 of the Standard Specifications for Construction and this special provision.

**b. Materials.** Apply permanent pavement markings as per sections 811 and 920 of the Standard Specifications for Construction and as defined in the contract.

**c. Construction.** Stripe the top course as directed by the Engineer and the following:

When striping the top course, use certified equipment capable of placing markings as required in subsection 811.03 of the Standard Specifications for Construction. It is the Contractor's responsibility to ensure their equipment applies a retroreflective uniform line on the top course that is clearly visible at night and is certified by the Department.

Do not use temporary Type R or Type NR tape for markings on the top course for CPM cold mill and one course hot mix asphalt overlay, and one course hot mix asphalt overlay projects unless directed by the Engineer.

At the end of each paving day, stripe the top course in their final configuration with Pavt Mrkg, Wet Reflective Type NR, Paint, 4 inch, (color), Temp prior to opening lanes to traffic.

Place permanent pavement markings as defined in the contract once all top course is placed. Removal of temporary markings is not to be completed unless directed by the Engineer, per the contract, or per the permanent pavement marking manufacturer specifications.

**d. Measurement and Payment.** All work will be paid for under the associated pay items used.

MICHIGAN  
DEPARTMENT OF TRANSPORTATION

SPECIAL PROVISION  
FOR  
**PAVEMENT MARKINGS ON CAPITAL PREVENTIVE MAINTENANCE PROJECTS -  
MICRO-SURFACING**

PMK:MKB

1 of 1

APPR:EMC:CRB:07-05-16

FHWA:APPR:07-13-16

**a. Description.** Ensure the completed work is in accordance with sections 811, 812 and 922 of the Standard Specifications for Construction and this special provision for the application of both temporary and permanent pavement markings on Capital Preventive Maintenance (CPM) Projects - Micro-surfacing only.

**b. Materials.** Use Pavt Mrkg, Wet Reflective, Type NR, Paint, 4 inch, (color), Temp on the leveling course only. Use Pavt Mrkg, Waterborne, \_\_ inch, (color) on the surface course before opening to traffic.

Do not use Type R tape for temporary markings on either the leveling or surface course on Micro-Surfacing Projects.

Apply Pavt Mrkg, Waterborne, 2nd application, \_\_ inch, (color), or a first application of Pavt Mrkg, Sprayable Thermopl, \_\_ inch, (color) after allowing the surface to wear for approximately 30 days or as determined by the Engineer.

**c. Construction.** Small self-propelled paint strippers may be used to apply temporary centerline and lane line markings on the leveling course only. Do not use these machines to apply an edge line. If striping an edge line on the leveling course, use certified equipment capable of placing markings as required in subsection 811.03 of the Standard Specifications for Construction.

Do not use small self-propelled paint strippers to mark the surface course. This equipment will not be certified by the Department. It is the Contractor's responsibility to assure their equipment applies a retro reflective uniform line on the leveling course that is clearly visible at night.

Leave these temporary markings in place for no more than 3 days. If the markings are in place for 3 days, on the 4th day the Contractor will either place the surface course or have the temporary markings on the leveling course retraced with Pavt Mrkg, Waterborne, \_\_ inch, (color), using certified equipment capable of placing markings as required in subsection 811.03 of the Standard Specifications for Construction.

**d. Measurement and Payment.** The completed work for **Pavt Mrkg, Wet Reflective, Type NR, Paint, 4 inch, (color), Temp** and/or **Pavt Mrkg, Waterborne, \_\_ inch, (color)** placed on the leveling course will not be paid for separately, but included in associated items.

**Pavt Mrkg, Waterborne, \_\_ inch, (color); Pavt Mrkg, Waterborne, 2nd application, \_\_ inch, (color),** or a first application of **Pavt Mrkg, Sprayable Thermopl, \_\_ inch, (color)** on the surface course only, will be paid for under the associated pay item.

MICHIGAN  
DEPARTMENT OF TRANSPORTATION  
  
SPECIAL PROVISION  
FOR  
**PERMANENT PAVEMENT MARKING MATERIALS**

PMK:MKB

1 of 1

APPR:MWB:CRB:07-07-16  
FHWA:APPR:07-13-16

**Delete the first paragraph of subsection 920.01, on page 890 of the 2012 Standard Specifications for Construction in its entirety and replace it with the following:**

Select pavement marking materials from the Qualified Products List unless specified otherwise by special provision in the contract. For black liquid shadow markings and blue markings used in parking areas, either choose a product of the specified binder material and color from the Qualified Products List or select a white product of the specified binder material from the Qualified Products List and tint the product to the appropriate color.

Use liquid applied pavement marking materials manufactured in the previous 12 months or within the shelf-life directed by the manufacturer, whichever is less. Use solid applied materials within the shelf-life directed by the manufacturer. Provide certification that liquid and solid applied pavement marking materials have been stored per the manufacturer's requirements. Materials not in compliance will be rejected and removed at the Contractor's expense.

**Delete the second paragraph from subsection 920.02.A, on page 891 of the Standard Specifications for Construction in its entirety and replace it with the following:**

Glass beads must meet the general requirements of subsection 920.02.B, and the applicable requirements for specific applications of subsection 920.02.C. All glass beads meeting subsections 920.02.B and 920.02.C to be used on Federal-aid projects must contain no more than 200 parts per million of arsenic or lead, as determined in accordance with *Environmental Protection Agency* testing methods 3052, 6010B, or 6010C.

**Add the following after the last paragraph of subsection 920.02.C, on page 892 of the 2012 Standard Specifications for Construction:**

6. **Modified Urethane.** The type, gradation, and application rates for glass beads used with modified urethane marking material must meet the modified urethane manufacturer's recommendation.

Use a double drop system of large and standard glass beads, a double drop system of ceramic elements and standard glass beads, or an Engineer-approved alternate for recessed longitudinal markings. Ensure large glass beads meet federal specification TTB-1325 for a Type 4 glass bead.



MICHIGAN  
DEPARTMENT OF TRANSPORTATION

SPECIAL PROVISION  
FOR  
**PAVEMENT MARKING MATERIALS**

OPR:JGM

1 of 1

C&amp;T:APPR:JAJ:DBP:06-17-10

**Delete the first paragraph in subsection 920.01.A, on page 848 of the 2003 Standard Specifications for Construction, in its entirety and replace it with the following:**

**A. Packaging and Labeling.** Furnish materials in containers or packages plainly marked, on the top and side, with a durable, weather-resistant marking, showing the name and address of the manufacturer, description of the materials, product identification number (if on the Qualified Products List the identification must match exactly), batch number, date of manufacture, expiration date, and volume and weight of contents. Use only liquid applied pavement marking materials manufactured in the previous twelve months, unless the shelf-life per the manufacturer is less than twelve months. Use those materials within the shelf-life directed by the manufacturer. Solid applied materials must be used within the shelf-life directed by the manufacturer. All liquid and solid applied pavement marking materials must be stored per the manufacturer's requirements. Provide certification that the materials being placed have been stored as required by the manufacturer. Materials not in compliance will be rejected and removed at the Contractor's expense.

**Add the following paragraph in subsection 922.04, on page 872 of the 2003 Standard Specifications for Construction:**

Furnish materials in containers or packages plainly marked, on the top and side, with a durable, weather-resistant marking, showing the name and address of the manufacturer, description of the materials, product identification (if on the Qualified Products List the identification must match exactly), batch number, date of manufacture, expiration date, and volume and weight of contents. Use only liquid applied pavement marking materials manufactured in the previous twelve months, unless the shelf-life per the manufacturer is less than twelve months. Use those materials within the shelf-life directed by the manufacturer. Solid applied materials must be used within the shelf-life directed by the manufacturer. All liquid and solid applied pavement marking materials must be stored per the manufacturer's requirements. Provide certification that the materials being placed have been stored as required by the manufacturer. Materials not in compliance will be rejected and removed at the Contractor's expense.

ATTACHMENT A  
INTERSECTIONS REQUIRING YEARLY PAVEMENT MARKINGS

1. Dunbar Road at **US24\***
2. Grafton Road at **Monroe Street**
3. Lakeside Road (Samaria Road) at **US24\***
4. Lewis Avenue at **M50\***
5. Lewis Avenue and Smith Road
6. Lewis Avenue and Sterns Road
7. Luna Pier Road at **M125\***
8. Mall Road at **M125\***
9. Mall Road at **US24\***
10. Nadeau Road and North Dixie Highway
11. Nadeau Road at **I75\***
12. Newport Road at **US24\***
13. North Dixie Highway and Sandy Creek Road
14. Plank Road at **Ford Plant**
15. Samaria Road and Secor Road
16. Secor Road and Smith Road
17. Smith Road and Jackman Road
18. St. Anthony Road and Secor Road
19. Sterns Road and Douglas Road
20. Sterns Road and Secor Road
21. Sterns Road at **US24\***
22. Sterns Road over **US23\***
23. Sterns Road and Summerfield Road
24. Stewart Road at **US24\***
25. Carleton Rockwood at **US24\***
26. Stewart Road/Cole Road at **M125\***
27. **US24** at Smith Road\*
28. Smith Road at Douglas Road
29. Raisinville Road at **M50\***
30. North Dixie Highway and Swan Creek Road
31. Albain Road at **US24**
32. Sterns Road and Monroe Road
33. Sterns Road and Whiteford Center

\* Please note that US24, US23, I75, M50 and M125 are all state roads and those approaches are not to be included in the scope of this project as they fall under the jurisdiction of MDOT to be maintained. Roads in **Bold** are also not to be included as they are under the jurisdiction of others.

ATTACHMENT B  
Names & Numbers for Village or City Striping

Village Of South Rockwood –	734-379-3683
Village of Maybee -	734-587-2900
Village of Dundee -	734-529-3430
City of Luna Pier -	734-848-6495
City of Milan -	734-439-1501
City of Petersburg -	734-279-1210
Village of Estral Beach -	734-586-8380

Please contact these agencies to see if they have any pavement marking work that they would like to have completed as part of this year's contract. They should receive our bid prices but be invoiced and pay for this work themselves.

### Railroad Crossings

Location	Date	Notes
<b>ASH TWP 001</b>		
Scofield-Carlton b/t Exeter & Burns		
Maxwell b/t Monroe & Scofield-Carleton		
2 RR Grafton b/t Will-Carlton & Monroe		
Romine b/t Newburg & Will-Carleton		
Labo b/t Maxwell & Grafton		
Sigler b/t Grafton & Maxwell		
Newburg b/t Grafton & Maxwell		
Briarhill b/t Carleton Rockwood & Newburg		
East Newburg b/t Grafton and Romine		
<b>BEDFORD TWP 002</b>		
Samaria b/t Lewis & Jackman		
Erie b/t Jackman & Lewis		
Lewis b/t Erie & Temperance		
Temperance b/t Lewis & Crabb		
Dean b/t Lewis & Crabb		
Sterns b/t Lewis & Crabb		
Crabb b/t US-24 & Sterns		
Lavoy b/t US-24 & M-125		
Sterns b/t US-24 and M-125		
<b>BERLIN TWP 003</b>		
2 RR Swan Creek b/t N. Dixie & I-75		
2 RR Newport b/t Brandon & Armstrong		
Armstrong b/t Newport & Labo		
2 RR Labo b/t N. Dixie & Brandon		
2 RR Sigler b/t N. Dixie & Armstrong		
N. Dixie b/t Sigler & S. Huron River dr.		
<b>VILLAGE OF S. ROCKWOOD (505-000-2005)</b>		
2 RR East & West Side of N. Dixie		
2 RR S. Huron River dr. b/t I-75 & Ready		
<b>DUNDEE TWP 004</b>		
Stowell b/t Village of Dundee & Rightmire		
Dixon b/t Wells & Gloff		
Gloff b/t Dixon & Dunbar		
Meanwell b/t M-50 & Eggert		
Dundee Azalia b/t Lafler & Radka		
<b>ERIE TWP 004</b>		
Victory b/t Cousino & Luna Pier		
Luna Pier b/t I-75 & M-125		
Erie b/t M-125 & Strasburg		
Erie b/t Summit & Bay Creek		
Bay Creek b/t Vienna & Sub Station		
Vienna b/t Bay Creek & Summit		
Dean b/t M-125 & Suder		
Suder b/t Dean & Sub Station		

Sterns b/t Suder & M-125		
Lotus b/t Suder & M-125		
Lakeside b/t US24 and M-125		
<b><u>EXETER TWP 006</u></b>		
Maybee-Scofield b/t Doty & Zink		
Zink b/t Maybee-Scofield & Steffas (Stop Bars)		
Sumpter b/t Steffas & Doty		
Scofield b/t Steffas & Doty		
S. Stony Creek b/t Steffas & Sumpter		
Exeter b/t Nolan & Scofield-Carleton		
<b><u>FRENCHTOWN TWP 007</u></b>		
2 RR Sandy Creek b/t Spaulding & N. Dixie		
2 RR Hurd b/t Vivian & Mentel		
2 RR Nadeau b/t I-75 & Fix		
Mentel b/t Nadeau & Fix		
2 RR N. Stony Creek b/t Mentel & Newport South		
Newport South b/t Post & Swan Creek		
Newport South b/t Post & N. Stony Creek		
2 RR Post b/t Mentel & Newport South		
Willaims b/t Post & N. Dixie		
N. dixie b/t Post & Fermi dr		
Swan Creek b/t I-75 & N. Dixie		
Stewart b/t US-24 & M-125		
Mall b/t US-24 & M-125		
LaSalle b/t US-24 & M-125		
Hurd b/t Reinhardt & US-24		
Heiss b/t Stumpmier & US-24		
Stumpmier b/t Heiss & US-24		
Steiner b/t S. Stony Creek & Reinhardt		
S. Stony Creek b/t Toben & Steiner		
2 RR Fix b/t Mentel & Hurd		
<b><u>IDA TWP 008</u></b>		
Ida West b/t Haines & Wells		
Albain b/t Haines & Douglas		
Lulu b/t Secor & Douglas		
Douglas b/t Lulu & Ida Center		
Ida Center b/t Jackman & Douglas		
Todd b/t Jackman & Douglas		
Morocco b/t Jackman & Douglas		
Rauch b/t Jackman & Lewis		
<b><u>LASALLE TWP 009</u></b>		
S Otter Creek b/t Goutz & M-125		
S Otter Creek b/t M-125 & Knab		
LaPlaisance b/t M-125 & Knab		
Kelly b/t Cousino & M-125		
Cousino b/t Victory & Kelly		
N. Otter Creek b/t M-125 & Goutz		
Swartz b/t US-24 & M-125		

Stein b/t US-24 & M125		
Wood b/t US-24 & M-125		
Rauch b/t US-24 & M-125		
<b>MILAN TWP 011</b>		
N. County Line b/t Cone & Milwaukee		
Cone b/t N. County Line & Far		
Dennison b/t Hickory & Welch		
Ostander b/t Ann-Arbor & Wells		
<b>MONROE TWP 012</b>		
2 RR Mortar Creek Hull & M-125		
2 RR Albain b/t M-125 & Hull		
Dunbar b/t US-24 & M-125		
Dunbar b/tM-125 & LaPlaisance		
2 RR LaPlaisance b/t Jones Ave. & I-75		
st Vincent off Kentucky ave 1 r		
Albain b/t US-24 and M-125		
<b>Raisinville TWP 013</b>		
Dixon b/t Nieman & Sullivan		
Stewart b/t Muehleisen & Ida-Maybee		
Ida-Maybee b/t Day & Stewart		
<b>SUMMERFIELD TWP 014</b>		
Ida Center b/t Alcott & Petersburg		
Sylvania Petersburg b/t Lulu & Ida Center		
Teal b/t Sylvania Petersburg & Lulu		
Albain b/t Anders & Summerfield		
Railroad st. b/t Summerfield & Elizabeth		
Ida West b/t Summerfield & US-23		
Summerfield b/t Ida West & Railroad st.		
Wells b/t Dunbar & Ida West		
<b>WHITEFORD TWP 015</b>		
Yankee b/t Memorial Hwy. & Clark		
Lynch b/t Memorial Hwy & Clark		

## TURN ARROWS & STOP BARS & ONLYS

LOCATION	DATE	NOTES
<b><u>Bedford Twp.</u></b>		
Smith & Lewis Turn Arrows & Stop Bars		
Smith & Jackman Turn Arrows & Stop Bars		
Smith & Summerfield Stop Bars		
Sterns & Monroe Turn Arrows & Stop Bars		
Sterns & Summerfield Turn Arrows & Stop Bars		
Sterns b/t Douglas & Summerfield 2-Turn Arrows		
Sterns & Douglas Turn Arrows & Stop Bars		
Sterns & Jackman Turn Arrows & Stop Bars		
Sterns & Lewis Turn Arrows & Stop Bars		
Sterns b/t Summerfield and Secor Arrows		
Dean and Douglas Stop Bars		
Lewis and Dean Stop Bars and Arrows and Onlys		
Sterns b/t Lewis and Crabb 2 Arrows		
Lewis b/t Sterns and Dean 2 Arrows and Onlys by MCCC		
Summerfield & Douglas Turn Arrows & Stop Bars		
Dean & Jackman Turn Arrows & Stop Bars		
Secor & Dean Stop Bars		
Secor & St. Anthony Turn Arrows & Stop Bars		
Secor & Samaria Turn Arrows & Stop Bars		
<b><u>Berlin Twp.</u></b>		
N. Dixie Hwy. & Swan Creek Turn Arrows, Stop Bars & Crosswalk		
Reaume and Turnpike Arrows and Stop Bars and Onlys		
S. Huron River Dr. & I-75 505-000-2005 Turn Arrows		
Westburn Golf Course S. Huron River Dr. 505-000-2097 Crosswalks		

<b><u>Frenchtown Twp.</u></b>		
N. Dixie Hwy. & Sandy Creek/Waterworks Turn Arrows & Stop Bars		
N. Dixie Hwy. & Nadeau Turn Arrows & Stop Bars		
N. Dixie Hwy. & Pointe Aux Peaux Turn Arrows & Stop Bars		
N. Dixie Hwy. & Fermi Dr. Stop Bars		
Wolverine & Nadeau Stop Bars		
Nadeau b/t Wolverine and I-75 Turn Arrows and Onlys		
Vivian at Nadeau Arrow		
Cole and Vivian Stop Bars		
Cole and Spaulding Stop Bars		
N Dixie b/t Hurd and N Stoney Creek Arrows		
Hurd and N. Dixie Stop Bars and Arrows and Onlys		
Newport b/t JoAnn and I-75 Arrows and Only		
Grand Blvd and N. Dixie Stop Bars and Only and Arrows		
Cole & Macomb Turn Arrows, Stop Bars & Crosswalks		
<b><u>Monroe Twp.</u></b>		
7th b/t Herr and US-24 Arrows and Stop Bars and Onlys		
East Dumbar b/t Hull and M-125 Arrows and Stop Bars and Onlys		
<b><u>Raisinville Twp.</u></b>		
Raisinville b/t M-50 and N. Custer Arrows and Onlys		
<b><u>Whiteford Twp.</u></b>		
Schinpke & Sterns Turn Arrows & Stop Bars		
Schinpke & Section Stop Bars		



**SCHOOL PAVEMENT MARKINGS**

LOCATION	DATE	NOTES
<b><u>Ash Twp.</u></b>		
Grafton b/t Sigler & Ready		
Carlton Rockwood & Briar Hill		
Labo & Exeter		
<b><u>Bedford Twp.</u></b>		
Smith East & West of Lewis		
Secor b/t Smith & State Line		
Douglas & Summerfield (cw)		
Jackman North & South of Dean (cw)		
Dean East & West of Jackman		
Monroe b/t Sterns & Summerfield (cw)		
Clegg West of Monroe		
<b><u>Berlin Twp.</u></b>		
Newport South b/t Swan Creek & Post		
Swan Creek & N. Dixie (cw)		
N. Dixie b/t Armstrong & Bomiea		
<b><u>Erie Twp.</u></b>		
Manhattan b/t S. Dixie & Connector		
<b><u>Frenchtown Twp.</u></b>		
Williams b/t N. Dixie & Post		
N. Stony Creek b/t N. Dixie & Newport South		
Nadeau b/t N. Dixie & Fix		
Cole & Macomb (cw)		
Vivian b/t Hurd & Nadeau		
<b><u>Ida Twp.</u></b>		
Lewis North & South of Lewis (cw)		
Ida st. East of Lewis (cw)		
<b><u>Monroe Twp.</u></b>		
Raisinville b/t Dunbar & M-50 ISD		
Raisinville b/t Dunbar & M-50 Meadow Mont.		
Herr b/t Dunbar & M-50		
Paterson b/t 7th & M-50 (cw)		
Western b/t 7th & M-50 (cw)		
Albain b/t US-24 & M-125 (cw)		
<b><u>Raisinville Twp.</u></b>		
Heiss & Gruber		
Raisinville b/t Stewart & Bluebush		
<b><u>Summerfield Twp.</u></b>		
Ida-West b/t Petersburg & Dixon		
<b><u>Whiteford Twp.</u></b>		
Consear & Syl. Petersburg		